



Motor Handbook

Authors: **Institute for Power Electronics
and Electrical Drives,
RWTH Aachen University**
Fang Qi
Daniel Scharfenstein
Claude Weiss

Infineon Technologies AG
Dr. Clemens Müller
Dr. Ulrich Schwarzer

Version: 1.01

Release Date: 29.08.2016



Contents

Introduction	4
Induction Machine (IM)	6
Motor Structure and Functional Description	7
Motor Characteristics and Motor Control	7
Notable Features and Ratings	20
Strengths / Weaknesses	20
Predominant Applications	20
Permanent Magnet Synchronous Machine (PMSM)	21
Motor Structure and Functional Description	22
Motor Characteristics and Motor Control	24
Notable Features and Ratings	28
Strengths / Weaknesses	28
Predominant Applications	28
Synchronous Reluctance Machine (SynRM)	29
Strengths / Weaknesses	30
Predominant Applications	30
DC Machine	32
Motor Structure and Functional Description	32
Motor Characteristics and Motor Control	34
Notable Features and Ratings	42
Strengths / Weaknesses	43
Predominant Applications	43
Brushless DC Machine (BLDC / electronically commutated motor)	44
Motor Characteristics and Motor Control	45
Strengths / Weaknesses	48
Predominant Applications	48
Switched Reluctance Motor (SRM)	49
Motor Structure and Functional Description	49
Motor Characteristics and Motor Control	51
Notable Features and Ratings	59



Strengths / Weaknesses	59
Predominant Applications	59
Stepper Motor	60
Motor Structure and Functional Description	60
Motor Characteristics and Motor Control	68
Notable Features and Ratings.....	70
Strengths / Weaknesses	70
Predominant Applications	70
Lexicon	71
Basic Principles of Electric Machines	71
Position Sensors in Electric Machines.....	78
Vector Control.....	82
Losses in Electric Machines	89
Efficiencies of Electric Machines	92
Temperature Classes of Winding Insulation	96
Cooling of Electric Machines	97
List of Abbreviations	98
List of Figures	99
List of Tables	102
References	103



Introduction

This "handbook of electric machines" gives a high-level orientation regarding the different kind of motors / generators, incl. their

- Structures and functionalities
- Characteristics and controls
- Notable features and ratings
- Strengths and weaknesses
- Predominant applications

The operation principles and characteristics of the different types of electric machines are explained using brief machine descriptions, diagrams, tables etc. In contrast to other documentations on electric machines complex mathematical descriptions are avoided wherever possible.

The handbook approaches the machine description from the perspective of a machine user (e.g. developers of electrical drive systems). Qualitative statements are avoided explicitly since the performance of an electric motor depends strongly on the respective application purpose, electromagnetic design and control setups. Hints to internal structures and architectural details have been limited as far as they are not required for the general description of machines and their operations. This handbook focuses mostly on the motoring operation of an electric machine. However, all types of the machines in this handbook can also be operated as generators.

The handbook follows a consistent structure. Each section uses the same documentation template, which enables the reader to quickly access the electric-machine related information one might be interested in. Control algorithms are explained in combination with the machine type they apply to. Common basics for electric machines, specific in background information are gathered in the chapter 'Lexicon'.

The following handbook has been developed in close collaboration with

Institute for Power Electronics and Electrical Drives (ISEA), RWTH Aachen University.

The content of this handbook is based on data originating from

- Lecture notes from ISEA
- Technical books of electric machines
- Freely accessible internet resources



Table 1 gives a brief comparison between the different machine types. The statements refer to a typical design from each type. The properties of a concrete machine depend strongly on the specific design, control method and application. All the pros and cons may not apply at the same time. This table cannot be used as the only criterion whether or not a motor type is the most suitable for a given application.

	IM	PMSM	SynRM	DC	BLDC	SRM	Stepper
Efficiency base-speed	+	++	+	--	+	-	-
Efficiency field-weakening	++	+	o	o	--	+	--
High-speed capability	++	+	-	o	+	++	--
Torque density	o	++	+	o	++	-	+
Power density	o	++	+	-	++	++	-
Control effort	+	-	o	++	+	--	++
Maintenance demand	+	+	+	-	+	+	+
Power factor	+	++	o	+	++	--	+
Cost	o	-	+	-	-	++	o
Rotor inertia	-	o	+	-	-	+	o
Noise	++	++	+	+	-	--	--
Torque ripple	++	++	+	++	+	--	-

Table 1: Comparison of different machine types



Induction Machine (IM)

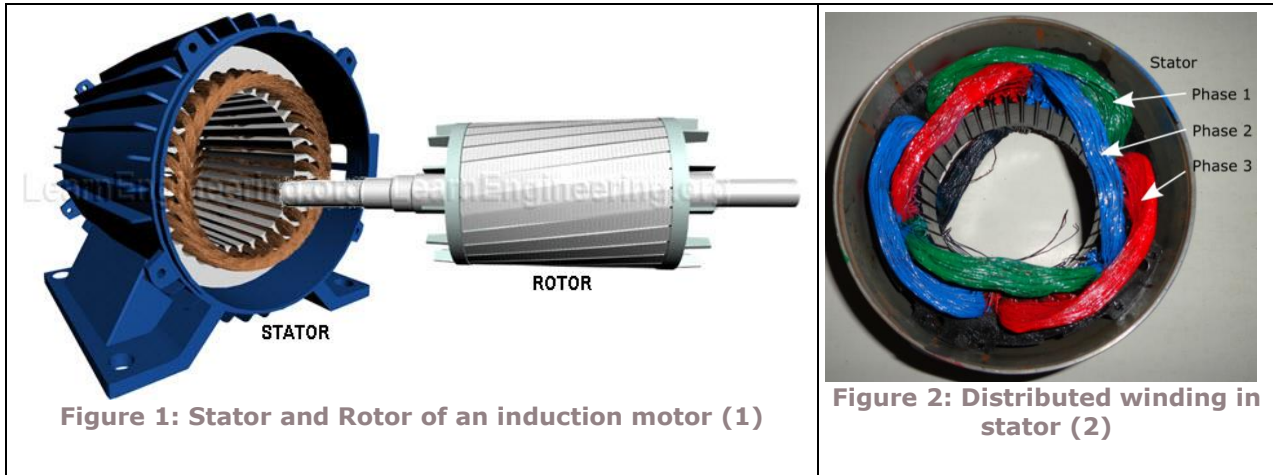

Figure 1: Stator and Rotor of an induction motor (1)

Figure 2: Distributed winding in stator (2)

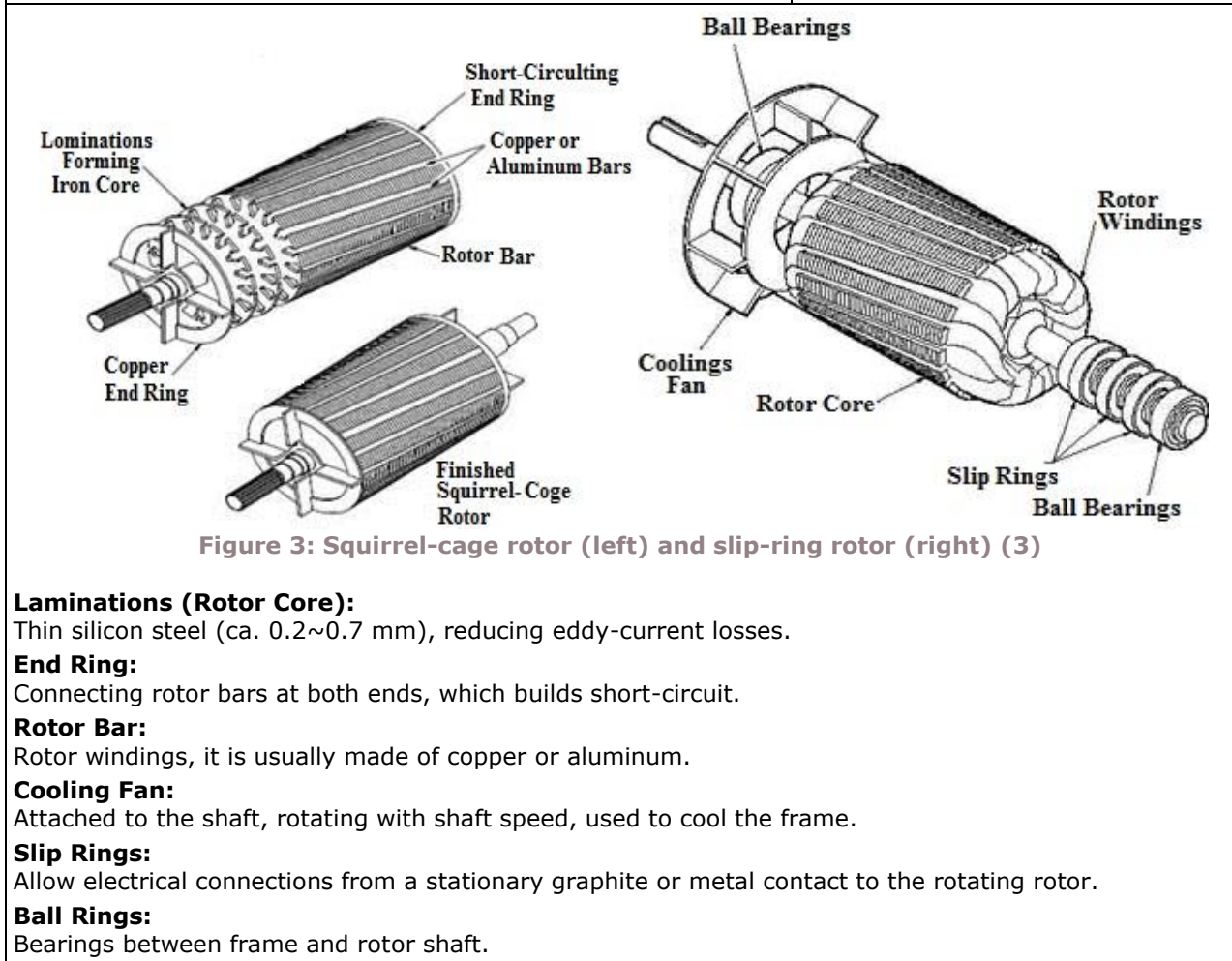

Figure 3: Squirrel-cage rotor (left) and slip-ring rotor (right) (3)

Laminations (Rotor Core):

Thin silicon steel (ca. 0.2~0.7 mm), reducing eddy-current losses.

End Ring:

Connecting rotor bars at both ends, which builds short-circuit.

Rotor Bar:

Rotor windings, it is usually made of copper or aluminum.

Cooling Fan:

Attached to the shaft, rotating with shaft speed, used to cool the frame.

Slip Rings:

Allow electrical connections from a stationary graphite or metal contact to the rotating rotor.

Ball Rings:

Bearings between frame and rotor shaft.



Motor Structure and Functional Description

Induction motors are also called asynchronous motors. They are the most commonly used electric machines.

Figure 1 shows the structure of the stator and the rotor. Figure 2 shows a three-phase one pole-pair distributed winding.

In general there are two types of rotors: the squirrel-cage rotor and the slip-ring rotor (Figure 3). The rotor windings in the squirrel-cage rotor are short-circuited at both ends by means of the end rings. In the slip-ring rotor, the rotor windings are not short-circuited, but accessible through the slip rings. External resistors can be connected to the rotor circuit, which improves the self-starting performance of the motor fed from grid (see Figure 5).

A rotating magnetic field is produced by the stator windings, which are connected to the grid or an inverter. As long as the rotating speed is not equal to the speed of the magnetic field, current will be induced in the rotor windings. According to the Lorentz law, a magnetic force arises on the rotor, which results in a torque production on the shaft.

Motor Characteristics and Motor Control

Commonly induction machines are directly connected to the grid. The typical torque-speed characteristic at a constant stator frequency and voltage is shown in Figure 4. The synchronous speed is the rotating speed of the stator magnetic field. At synchronous speed, no torque is produced by the motor. If the rotor rotates at a lower speed than the field, the motor runs in motoring mode. Otherwise, the motor operates in generating mode. The maximum torque, which can be produced by the motor, is called pullout torque. The nominal torque is conventionally half of the pullout torque. The motor usually operates in the linear region between the positive and the negative nominal torque, which is marked with the green line.

The difference between the rotor frequency and the rotating frequency of the magnetic field in the stator is defined as slip frequency f_{slip} . Slip is the ratio between slip frequency and the stator magnetic field frequency, $s = \frac{f_{\text{slip}}}{f_{\text{stator}}}$. The slip or the slip frequency is usually used to identify the operating point of the motor. At 0 rotor speed, the slip is 1. While at synchronous speed, the slip is 0.

The electrical rotor frequency f_{rotor} and the mechanical rotor frequency f_{mech} are linked by the pole pair number p by the equation $f_{\text{rotor}} = p \cdot f_{\text{mech}} = p \cdot \frac{n}{60 \frac{\text{s}}{\text{min}}}$ with the



speed n in rpm. Consequently, the electrical torque T_e and the mechanical torque T_{mech} are linked by the pole pair number p , too, by the equation $T_e = \frac{1}{p} \cdot T_{\text{mech}}$.

In other words, a higher pole pair number leads to a higher mechanical torque T_{mech} for the same electrical torque T_e . At the same time, this leads to a lower mechanical rotor frequency f_{mech} for the same electrical rotor frequency f_{rotor} .

The pole pair number is a machine constant and normally not changeable. However, there are machines with switchable pole pair number. This is usually realized by implementing two different windings in the stator, one for lower speed and one for higher speeds. For example, if the first winding has a pole pair number of 2 and the second winding a pole pair number of 8, a speed spread factor of 4 is achieved. For a grid connected machine (50 Hz), this would lead to synchronous speeds of 1500 rpm for the winding with $p = 2$ and 375 rpm for the winding with $p = 8$.

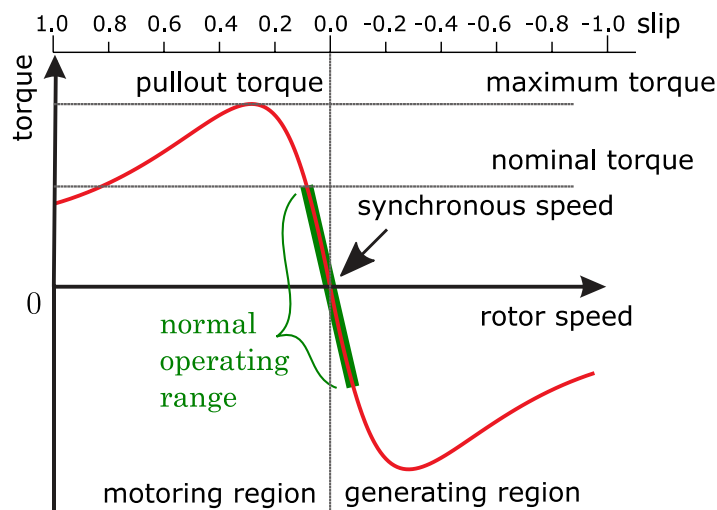

Figure 4: Torque-vs.-speed diagram of the IM (4)

There are only limited control possibilities for grid-connected induction motors. The slip-ring rotor allows the connection of external resistors to the rotor circuit. The dependence of torque-speed characteristics on rotor resistance is shown in Figure 5. The black arrow indicates an increasing rotor resistance in the pointed direction. Hence, increasing the rotor resistance leads to a higher starting torque. Figure 5 demonstrates an operating curve, indicated in blue, by means of three times resistor switching. Once the machine is running at its normal operational speed, the external resistors are disconnected to reduce the rotor cage resistance and therefore also the rotor losses. The operation of the machine indicated in the figure starts at standstill, e.g. zero rotor speed. It starts acceleration with nominal torque



(intersection of the blue line with the torque axis on the left-hand side) and switches the first time when the new configuration allows operating at nominal torque again.

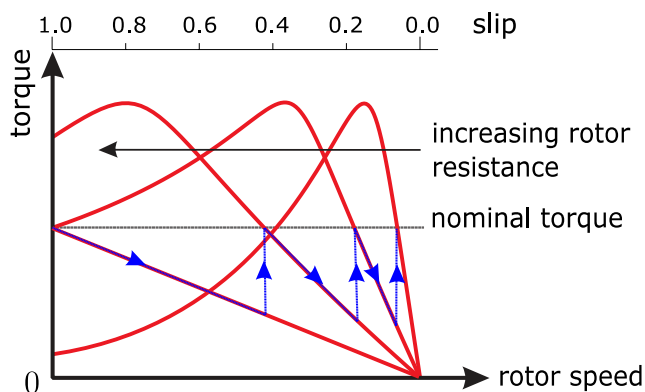

Figure 5: Influence of the rotor resistance (4)

The starting torque of the squirrel-cage rotor can be increased by shaping the rotor bars. Figure 6 shows the motor characteristics of different rotor bar shapes. The reason for this is the change of the rotor resistance due to the skin effect at different slip frequencies. With increasing slip frequency, thus increasing slip, the skin effect leads to a changed current distribution in the conductors such that the current density is largest near the surface of the conductor. As a consequence, this leads to a different ohmic resistance of the conductor dependent on the slip and on the geometric shape of the conductors.

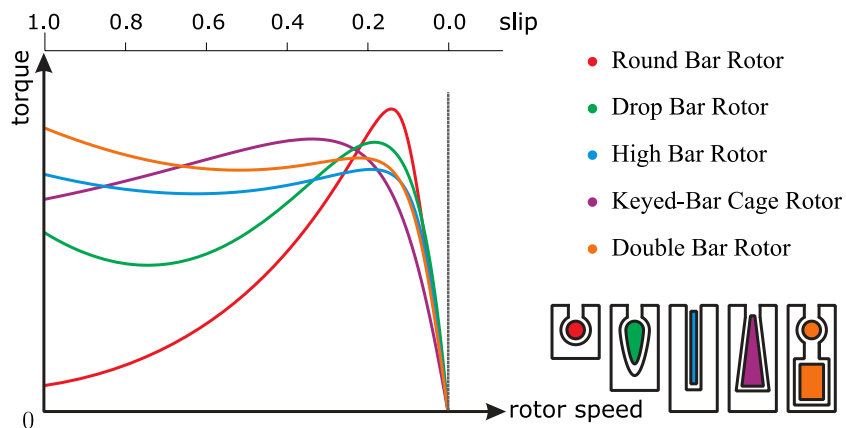

Figure 6: Influence of the shape of rotor bars (4), (5)

In order to limit the starting current of the motor, star-delta starting can be used for grid fed induction machines. The induction machine is started in star connection and



later switched to delta connection. This reduces the starting peak current to one third (see Figure 7). However, the starting torque is also reduced to one third. The switching from star to delta connection is commonly realized with contactors as shown in Figure 8. The contactor K1 enables the connection of the machine with the primary terminals U1, V1 and W1 to the grid. On startup, the contactor K2 has to be closed in order to establish a star connection of the machine. After startup, the contactor K2 is opened and the contactor K3 is closed at the same time instant. Hence, the delta connection of the phases is established.

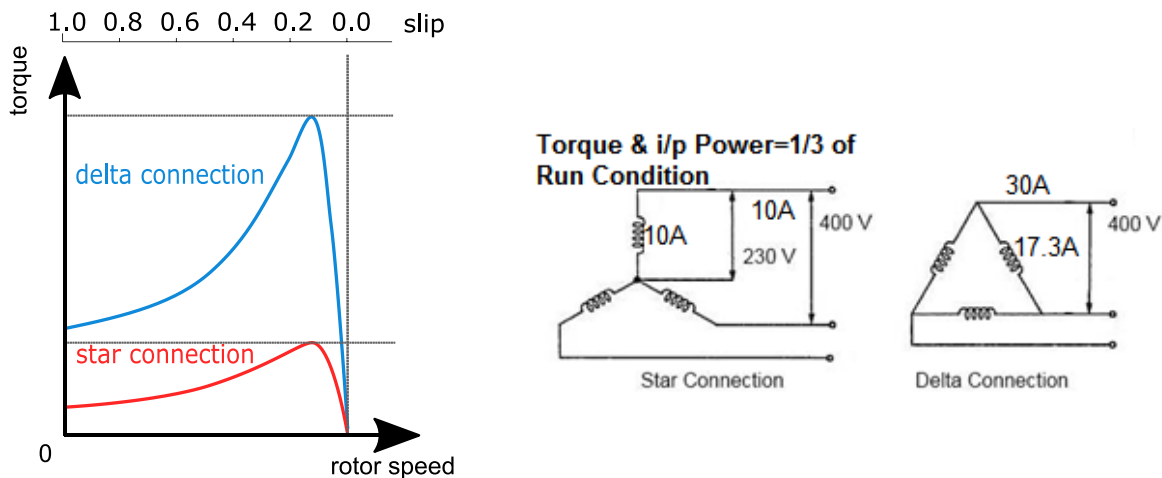

Figure 7: Star- and delta-connected IM (4)

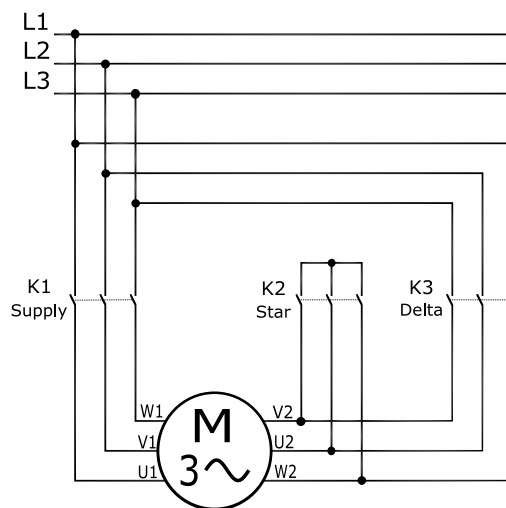

Figure 8: Star-Delta-Switching using contactors (4)



Nowadays, the induction machine is more often used as a variable speed drive. In such a case commonly a B6C inverter is used. Different control strategies exist for variable speed inverter-driven induction machines.

In the past, mainly the rather simple voltage-to-frequency (V/f) control was used and it can still be found in many industrial drives (6). The main drawback is its limited dynamic performance. When keeping the ratio between stator voltage and stator field frequency constant, the torque curve can be shifted along the speed axis with constant stator flux and constant pullout torque as shown in Figure 9. This principle is easily realized in PWM-converters. The reference stator voltage amplitude as well as the reference stator frequency is calculated based on the torque reference and the measured speed of the machine. When the reference torque is kept constant, the ratio between stator voltage and stator field frequency are kept constant in such a way that the reference torque value is set independent of the actual rotor speed.

Based on the reference stator voltage and the stator reference frequency, the 3-phase voltage values obtained. Figure 9 demonstrates the motor acceleration with half nominal torque. During the acceleration of the rotor, the stator field frequency is set to f_1 at starting and increases to f_2 and then to f_3 , so that the operating point always stays within the linear region on the current operating curve as explained in Figure 4.

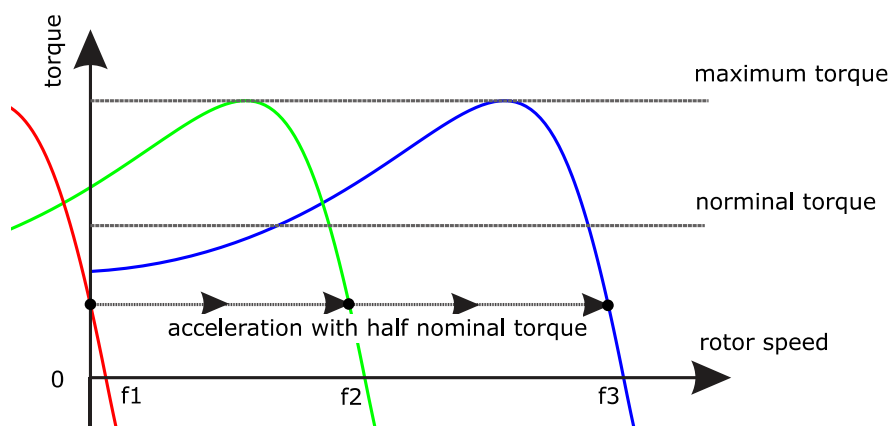

Figure 9: Torque for V/f control (4)

Another control strategy for inverter-fed variable-speed drives is the Field Oriented Control (FOC), a type of vector control whose principles were developed around 1970 (7), (8). The name vector control originates from the basic principle of this type of control strategies. The time-dependent instantaneous 3-phase system



values, such as currents and voltages, are transformed into an orthogonal 2-dimensional coordinate system by means of the Park transformation (6). This coordinate system rotates with the same frequency as the 3-phase values. From this the three AC quantities are reduced to two DC quantities which, in general, are much simpler to control. The two DC quantities can be represented as a "space vector" in the two-dimensional coordinate system. This transformation results in a controllability of torque of the induction machine that is similar to the DC machine.

It is important to consider at this point, that for field oriented control, current is controlled in such a way that the desired operating point is reached. Consequently, this operation principle differs from grid connected machine operation as shown in Figure 4. The torque-vs.-speed diagram is different as all possible (speed/torque) points in the operating range (see Figure 11) are accessible.

For field oriented control, the abscissa of the two-dimensional coordinate system, called direct axis, is aligned with the magnetic flux in the induction machine. This allows an independent control of flux linkage via the direct or d current i_{sd} and torque via the quadrature or q current i_{sq} . The total stator current is $i_s = \sqrt{i_{sd}^2 + i_{sq}^2}$.

Based on reference values of torque (T_e^*) and flux linkage (ψ_M^*), which depend on the actual machine parameters as well as on the operating point, reference values for d and q current are calculated. They are compared to the measured d and q current values. A current controller, mostly a PI regulator, then calculates the reference d and q voltages. They are finally transformed back to instantaneous 3-phase coordinates to calculate the duty cycles for the inverter. The frequency of the reference currents (stator frequency) $f_{stator}^* = f_{rotor} + f_{slip}^*$ is the sum of the electrical rotor frequency f_{rotor} , which is the mechanical machine speed times the pole pair number, $f_{rotor} = f_{mech} \cdot p = \frac{n}{60 \frac{s}{min}} \cdot p$ with n being the speed in rpm, and of the reference slip frequency f_{slip}^* , which is a function of reference torque and reference flux linkage, e.g. the two input variables of the controller. To sum up, the stator frequency is defined by the values of mechanical speed, pole pair number, reference torque and reference flux linkage.

Based on the reference slip frequency and the mechanical rotor position, the angle θ_M^* is calculated for the transformation of the reference d and q current to the 3-phase reference current values that the converter has to set. This principle is summed up in the FOC control scheme in Figure 10.

The easiest way for normal motoring operation is to set a constant d current to obtain a constant flux linkage in the machine. The q current is set directly



proportional to the torque command. As a consequence, even at zero torque request, the machine is fed with current to obtain the magnetization and, thus, flux linkage. This allows to ramp up torque at any time instant. Without flux linkage in the machine, no torque can be produced.

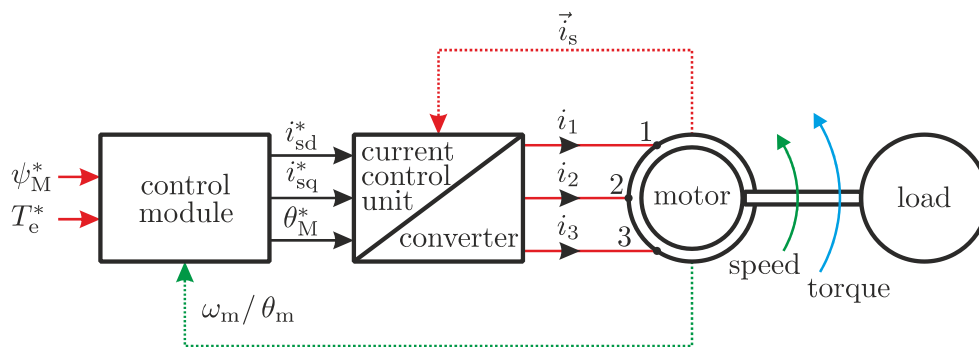

Figure 10: Field-oriented control drive structure (6)

In motoring mode, the induction machine is capable of delivering a constant nominal torque over a defined speed range called base speed until the nominal speed is reached, see Figure 11. At this point, also called corner point, the machine reaches its nominal power and the induced back emf in the machine reaches the same amplitude as the maximum output voltage of the inverter. The speed cannot be increased further at the same torque level as the currents cannot be increased. The base speed value depends on the maximum current and voltage limits as well as on the induction machine parameters.

One possible solution to overcome this speed limit is the application of field-weakening. The main idea is to reduce the flux linkage in the machine and, thus, the induced back emf. Using field oriented control, this is easily done by reducing the direct current reference value to reduce the flux linkage. The reduction of the direct current leads to an increased slip frequency at the same torque reference. Consequently, the stator frequency increases, too.

With a reduced induced back emf, it is again possible to increase the speed further. However, the nominal torque is no longer reached as this would exceed the nominal power. Consequently, the speed dependent maximum torque values for speeds above the nominal speed are defined by the speed and the nominal power according to the mechanical power equation $P = 2\pi \cdot T \cdot n$, hence $T = \frac{P}{2\pi \cdot n}$. In the torque-vs.-speed diagram (Figure 11), this operating range is clearly visible as the maximum torque decreases with inverse speed as indicated by the formula above.



In Figure 11, a third speed range above the field weakening range is visible. This range is limited by the maximum theoretically available power which is defined by the pullout torque and in this range, torque is proportional with inverse squared speed, $T \sim \frac{1}{n^2}$. This is due to the pull-out torque having the same proportionality. As operation near or even at pullout torque is normally avoided, this extended field weakening range is almost never used in practice.

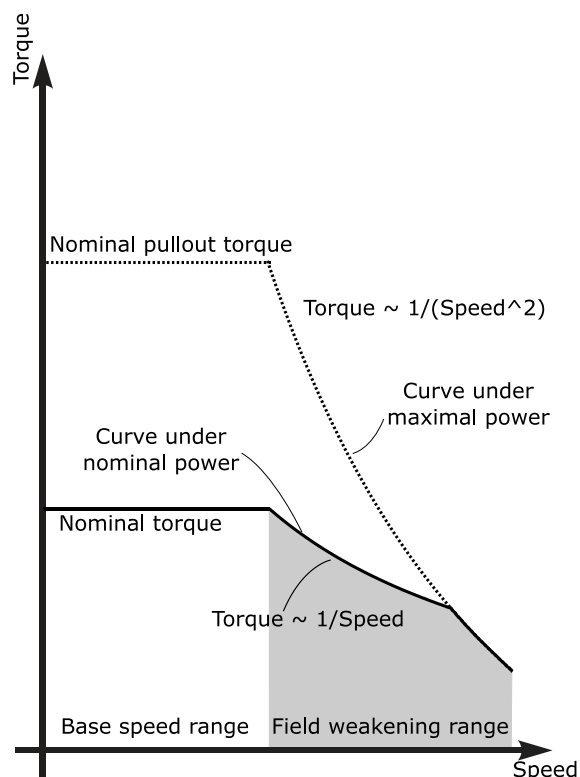

Figure 11: Operating range of the induction motor (4)

When the induction machine is operated as described above, it exhibits rather low efficiency in partial load as the nominal flux linkage is kept constant even at zero load. This results in the normalized stator current (current divided by nominal current) and power factor shown in Figure 12. This figure is valid for grid connected machines, too. The same behavior is depicted in the upper part of Figure 13, where the reference flux linkage, which is directly proportional to the magnetizing current, is shown dependent on rotor speed and torque. In the base speed region (below $n = 1500$ rpm in the figure), flux linkage and, hence, the magnetizing current is kept constant resulting in a low power factor at partial load. A way to optimize the partial load efficiency is to do field weakening as described above for speeds larger than base speed in the base speed region, too. The lower part of Figure 13 depicts this strategy: At partial load and, hence, low torque, the flux linkage reference value is



reduced. This directly reduces the magnetizing current at these working points and leads to a higher power factor and efficiency. A downside of this strategy is a loss in machine dynamics as the creation of flux linkage depends on the rotor time constant which can easily be in the millisecond range.

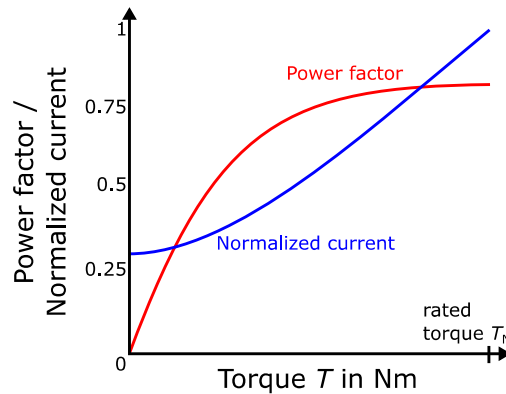
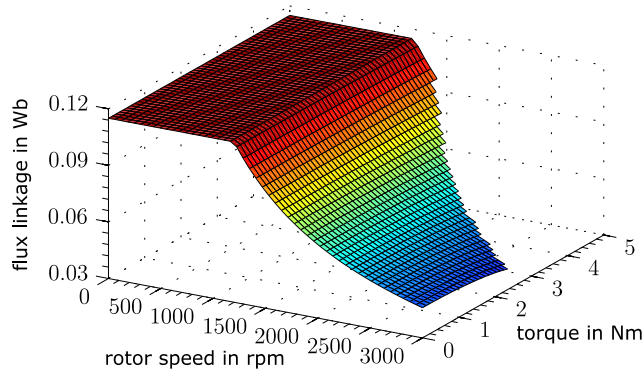
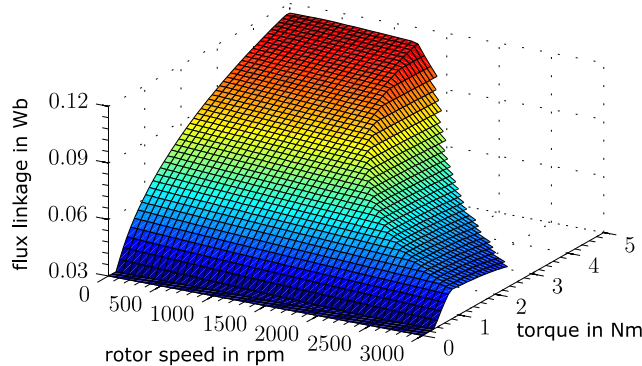

Figure 12: Normalized current and power factor over torque (4)



(a) constant flux linkage reference value in base speed region



(b) optimized flux linkage reference values

Figure 13: Constant (a) and optimized (b) flux linkage reference values over speed and torque (4)



Name plate data and derived characteristic values

Induction machines usually provide its most important data on a name plate on the machine. An example is shown in Figure 14 with a numbering of the available parameters on the left and on the right.

1	Motorenwerke ACME	IE3	7
2	ASM 100L-2	0123456	8
3	Δ 400 V	5,76 A	9
4	3 kW	$\cos(\varphi)=0,86$	10
5	2890 rpm	50 Hz	11
6	Isol. Kl. F	IP 44	12

Figure 14: Name plate of an induction machine (9)

The information given on the name plate is as follows (9):

Field number	Symbol	Description	Remark
1		Manufacturer	
2		Motor type	Type designation of the manufacturer, can include Size or pole number (here: 2 poles $\Leftrightarrow p = 1$ pole pair)
3	V_N	Nominal voltage	Line to line voltage
4	P_N	Nominal power	Allowed continuous mechanical output power
5	n_N	Nominal speed	Speed at nominal torque load
6		Isolation class	Temperature stability of the winding (see Lexicon)
7		Efficiency class	(see Lexicon)
8		Serial number	
9	I_N	Nominal current	At nominal voltage and nominal power
10	$\cos(\varphi_N)$	Power factor	Phase angle at nominal voltage and nominal power
11	f_N	Nominal frequency	
12		Protection class	Protection against intrusion of debris and water

Table 2: Description of the name plate data of the induction machine (9)



Based on these values, different other characteristic values can be derived:

Formula	Unit	Description	Example
$n_0 = \frac{f_N \cdot 60 \frac{s}{\min}}{p}$	rpm	Synchronous speed or no-load speed	3000 rpm
$\Omega_{\text{mech}} = n_N \cdot \frac{2\pi}{60 \frac{s}{\min}}$	rad/s	Nominal mechanical angular speed	$302,6 \frac{\text{rad}}{s}$
$T_N = \frac{P_N}{\Omega_N}$	Nm	Nominal mechanical torque	9,9 Nm
$P_{N,\text{el}} = \sqrt{3} \cdot U_N \cdot I_N \cdot \cos(\varphi_N)$	W	Nominal electrical power	3432 W
$\eta_N = \frac{P_N}{P_{N,\text{el}}}$		Efficiency	87,4%
$P_{\text{loss},N} = P_{N,\text{el}} - P_N$	W	Losses	432 W
$I_{\text{active},N} = I_N \cdot \cos(\varphi)$	A	Active current	4,95 A
$I_{\text{reactive},N} = I_N \cdot \sin(\varphi)$	A	Reactive current	2,94 A

Table 3: Basic formulas of the induction machine (9)

Other Types of Induction Machines

The squirrel-cage and the slip-ring 3-phase induction machine are the most commonly used induction machines. However, other configurations are available and will be shortly presented here.

The doubly-fed induction machine is similar to the slip-ring machine. Instead of connecting resistors to a 3-phase winding in the rotor, the windings are fed by an inverter. This machine type is commonly used as a wind turbine generator, see Figure 15, as an alternative to, for example, synchronous generators. Its main benefit is the possibility to connect the stator side of the generator directly to the grid instead of having to use a full-scale inverter for the nominal wind turbine power rating. The direct grid connection implies a constant electrical stator frequency. This constraint is fulfilled even with varying mechanical frequency. This happens, for example, when a gust of wind hits a wind turbine. By varying the frequency of the rotor winding supply, which has a much smaller power rating than the stator side, it is possible to keep the stator frequency constant at the grid frequency while the mechanical frequency rises during the wind hug. Another benefit of this machine type is that it is able to produce positive and negative reactive power and can, thus, be used to stabilize a grid.

In Figure 15, one can easily identify the 3-phase stator side connection to the grid. This is the main power output of the generator, which is driven by the rotor blades



with a gearbox between rotor blades and the rotor side of the generator. As described, the 3-phase rotor winding is supplied by a grid connected inverter to allow a free setting of frequency and phase of the rotor currents.

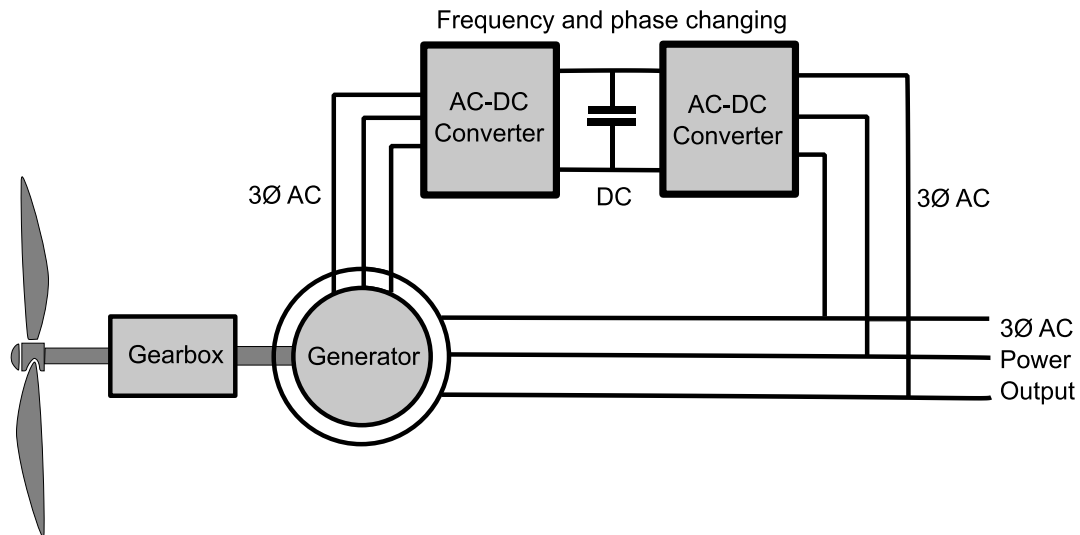

Figure 15: Doubly-fed induction generator connected to a wind turbine (10)

Besides 3-phase operation, induction machines are available to be used as a single-phase machine, too. As any electrical motor, the induction machine requires two fluxes with a phase angle greater than zero to produce torque (see Lexicon for further explanation). In a single-phase, the AC supply leads to an alternating stator current in the winding (run winding) and, thus, to an alternating main flux. As the main flux interacts with the rotor it induces a current in the rotor which produces the rotor flux. At standstill, no torque can be produced without an initial rotation which is mechanically not possible due to standstill and electrically not possible due to the alternating but not rotating current / flux. A solution for this problem is the addition of a second winding (auxiliary winding) to the stator of the induction machine. This winding is connected to the grid with an additional external capacitor which provides a current phase shift compared to the current in the first winding. The addition of both, the flux from the first winding and the phase-shifted flux of the second winding, is a rotating flux which enables the single-phase induction machine to produce torque at standstill and, hence, to start up the machine. Once the machine is rotating, the auxiliary winding can be disconnected to increase efficiency and running smoothness of the motor as the rotation provides the phase shift between stator and rotor flux and, consequently, the production of torque. The rotation direction can be set by the position of the capacitor in front or after the auxiliary winding as can be seen in Figure 16.



Once the motor has begun to rotate, it will accelerate until its stable operation point is reached. When connected to a load, e.g. a fan, this will be the point where the load torque is equal to the machine torque at a speed below base speed. Without any load, the machine accelerates until slightly below base speed, where a small torque is needed to compensate the friction of the machine.

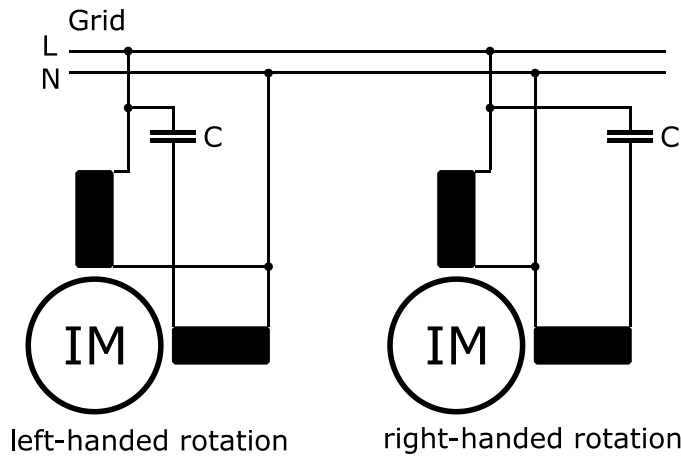

Figure 16: One-Phase Induction Motor as Capacitor Motor (4)



Notable Features and Ratings

- Currently the most commonly used machine type in industry (11)

Strengths / Weaknesses

- The IM has a good power factor of 0.75 – 0.9 (12)
- The ratio of nominal speed to maximum speed for induction machines is between 3 to 5 due to its reasonable field-weakening range
- High pull out torque compared to nominal torque (commonly a factor of around 2), allowing a fast acceleration
- High startup current for grid connected machines (may require star-delta-switching or one of the other methods described in this chapter)
- In contrast to permanent magnet synchronous machines, the induction machine is more efficient in field weakening operation. (6)
- Lower efficiency compared to permanent magnet synchronous machine in base speed as all the machine flux has to be generated by exciting the windings (no magnets).
- Generally lower efficiency than synchronous reluctance machines or permanent magnet synchronous machines as the induction machine has additional rotor losses (ohmic losses).

Predominant Applications

The most common industrial motor used today: as direct grid connected and variable speed drive.

Pumps, fans, trains, automation etc.

In the future it will be replaced more and more by the synchronous reluctance (pump applications) and permanent magnet synchronous machine, due to higher efficiency of these two synchronous machine types. The induction machine continues to have its strength especially in applications with high field weakening operation.



Permanent Magnet Synchronous Machine (PMSM)

Synchronous machines can be divided into two types of machines, the non-salient and salient type machine.

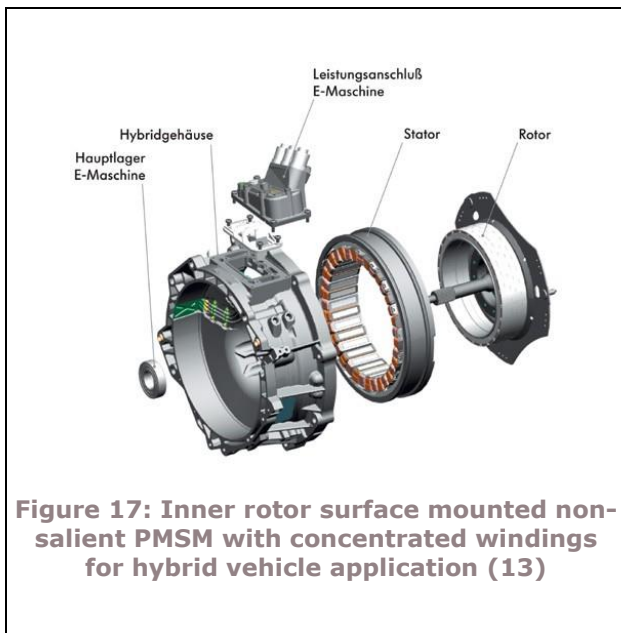

Figure 17: Inner rotor surface mounted non-salient PMSM with concentrated windings for hybrid vehicle application (13)

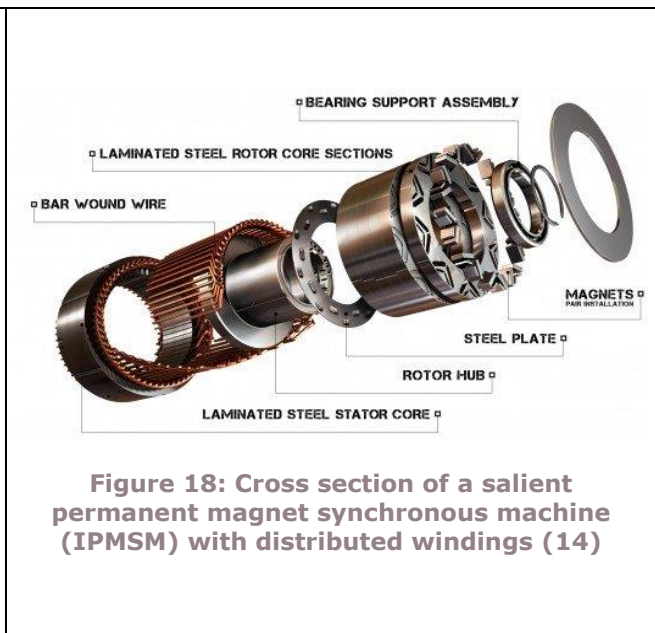

Figure 18: Cross section of a salient permanent magnet synchronous machine (IPMSM) with distributed windings (14)

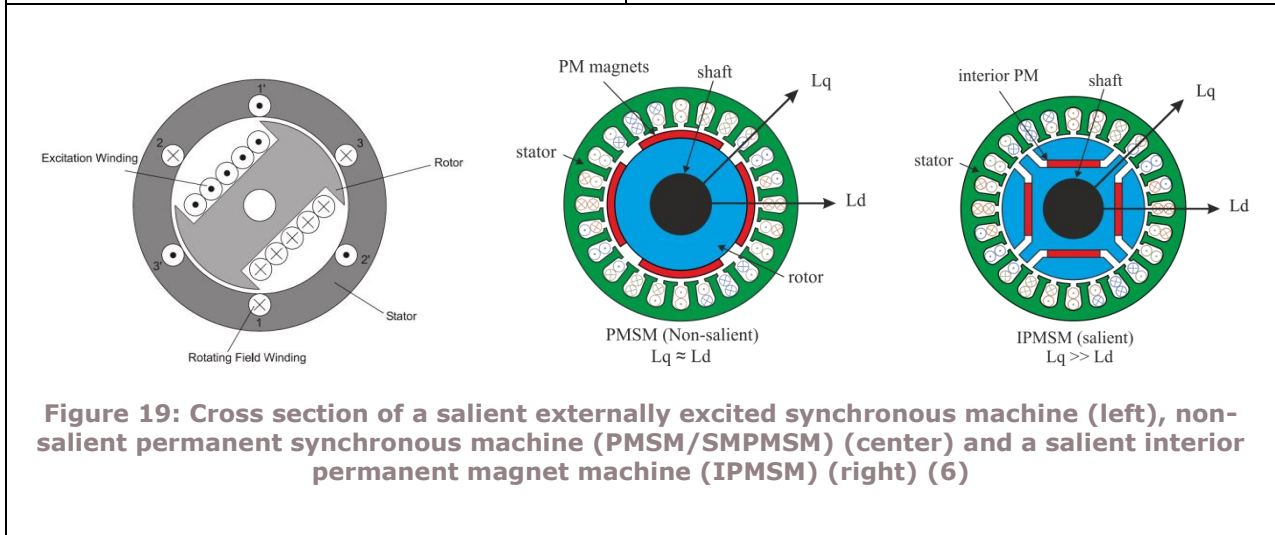

Figure 19: Cross section of a salient externally excited synchronous machine (left), non-salient permanent synchronous machine (PMSM/SMPMSM) (center) and a salient interior permanent magnet machine (IPMSM) (right) (6)



Motor Structure and Functional Description

Similar to DC machines, synchronous machines can produce torque when a rotating electromagnetic field and a constant field are standing still relative to each other. To develop a constant torque in a synchronous machine, the stator field must rotate synchronous with the rotor because the excitation winding and its field are fixed to the rotor. The field excitation winding is mounted in the rotor of the synchronous machine. The rotor is excited by a DC power supply via slip rings (Figure 19, left) or, more commonly, by permanent magnets (Figure 19, center and right).

As the rotor field rotates with the mechanical speed of the rotor, the stator winding must generate a rotating field. Consequently, the stator has to have a rotating field winding. In Figure 19 the winding direction (direction of current flow) is shown by a dot (into the surface) and cross (coming out of the surface) within the stator slots. The center and right figure both have a two layer 3 phase winding which allows an overlap of the adjacent phases and therefore also a sinusoidal stator field in the air gap.

The d-axis (Figure 19 i.e. L_d) refers to the direct axis (main flux path axis i.e. normally in orientation of the permanent magnets) of a synchronous machine, while the q-axis (L_q in Figure 19) refers to the quadrature axis. Depending on the rotor geometry, the synchronous machine is either a non-salient type (Figure 19 center) i.e. the stator inductance is not dependent on the rotor position or a salient type machine (Figure 19 right), where the stator inductance is dependent on the rotor position. In salient pole synchronous machines the stator inductance is rotor position dependent ($L_q \gg L_d$), resulting in a reluctance force. The different inductances can be influenced by the rotor geometry and are due to the difference in magnetic properties of the materials used in the rotor i.e. magnets and air have a magnetic relative permeability μ_r of 1, while electrical steel a μ_r ca. 4000-10000. In addition, salient pole machines have a better field weakening capability due to their difference in d- and q-inductances. Due to the rotor saliency, IPMSM torque depends on both d- and q- current components.

Figure 17 shows an example of a surface mounted non-salient permanent magnet synchronous machine. The size i.e. motor length and diameter of the machine (diameter \gg length) is typical for hybrid electric vehicle application. The machine has a large diameter and small axial length because it normally is directly connected to the gearbox in the automobile i.e. motor has the same diameter as the gearbox. Figure 18 on the other hand shows a more common diameter to machine length ratio. This machine has distributed windings with interior permanent magnets (V-shaped magnets in the rotor) causing a saliency and therefore also reluctance torque i.e. salient machine.



Concentrated and distributed windings

Synchronous machines can either have distributed or concentrated windings. With concentrated windings all conductors are in one slot and span one pole i.e. have a span of one, as can be seen in Figure 18 and Figure 20 (top). Distributed windings have a span greater one. In Figure 19 (right) for example each winding spans 6 slots, while in Figure 20 (bottom) the span is 3. Furthermore, concentrated windings of different phases do not overlap, while distributed windings do, as can be clearly seen in Figure 20. Concentrated windings use less copper and have shorter end windings. In Figure 20 the two images on the right show how much longer the copper end windings are compared the rotor length. The distributed windings shown in the bottom, right image shows much larger end turns. Because, the slot span of the windings is lower in concentrated windings, less copper is necessary to connect the windings. Thus the concentrated windings can be built in a compacter way and uses less copper (therefore, cheaper).

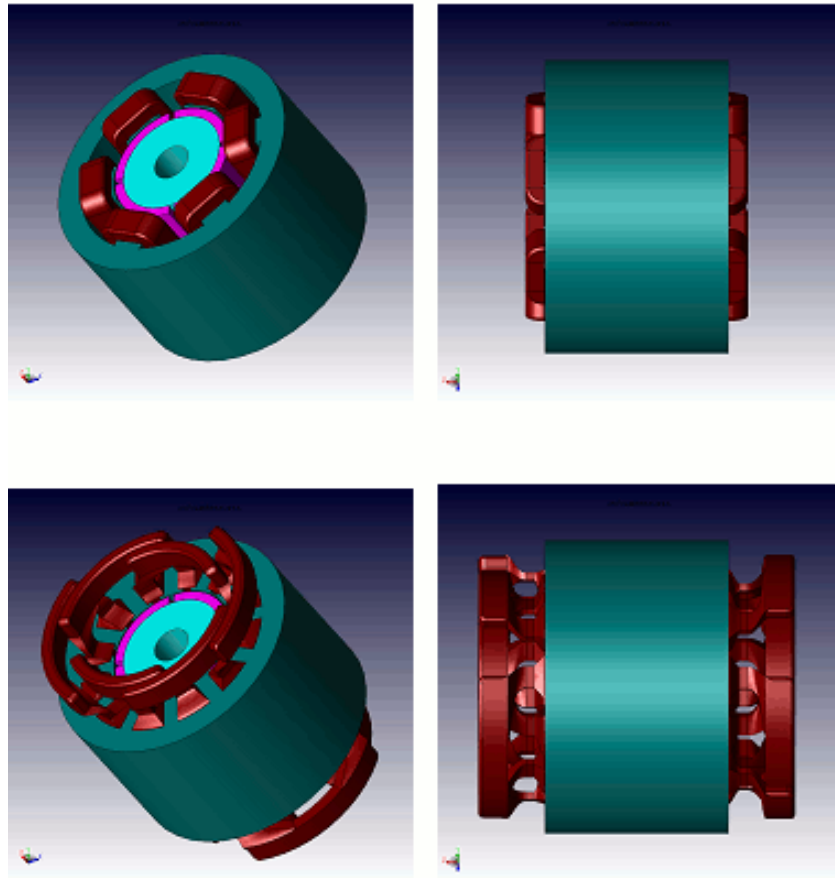

Figure 20: Concentrated (top) vs. distributed (bottom) windings (15)



However, distributed windings are still the predominant winding type due to their superior performance, generally attributed to a lower harmonic content as the spatial waveform of the excited flux is improved compared to concentrated windings (almost sine). The distributed windings are wound in such a way, to produce a near constant rotating stator field. Due to increased cost pressure on motor manufacturing, the easier and therefore cheaper to manufacture concentrated windings have become more popular.

Motor Characteristics and Motor Control

The load angle describes the angle between the rotor and stator fields. Figure 21 shows the sinusoidal dependency of torque on the load angle ϑ . This relationship is only valid when all voltages remain constant. The magnitude of the pull-out torque (maximum torque of the machine) can only be varied by varying the excitation current i.e. in a separately excited PMSM. If the excitation current is constant then the load torque will determine the load angle ϑ . In Figure 21 the dependence of the torque from the load angle is shown. If the two fields are perpendicular ($\vartheta = \pm\pi/2^\circ$), the highest torque is produced. If the two fields are aligned ($\vartheta = 0^\circ$), no torque is produced. From Figure 21 it can be derived that a static load torque, which would be larger than the pull-out torque, would force the load angle outside the stable operating area leading to a pole slip. In motor mode, the synchronous machine would come to stand still. In generator mode, the machine would accelerate and go in over speed.

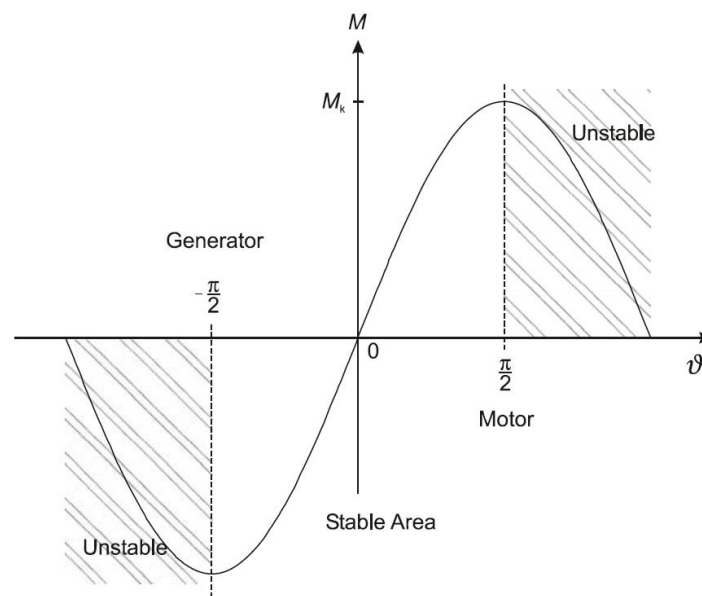

Figure 21: Torque as a function of load angle at constant voltage operation (4)



To operate a synchronous machine at different torque/speed-points, it is necessary to adjust voltage (or current) and frequency. An electrically excited machine can also control excitation current or excitation flux linkage i.e. influences the produced back emf.

Modern drives with synchronous machines are mostly fed by frequency converters to generate a three-phase system with variable frequency and voltage (or current). Consequently, it is possible to control the speed and torque.

Some control methods try to regulate the synchronous machine such that, for example, the synchronous machine only requires active power or pure reactive power (synchronous compensator, inductive or capacitive). Some controllers maximize torque for a given stator current (Maximum Torque Per Ampere). In the following different controls are mentioned in more detail.

Operation under active power control (non-salient PMSM with excitation windings)

To maximize utilization of the inverter's apparent power (kVA), synchronous machines can be operated at unity power factor i.e. $\cos\varphi = 1$. With this control method, the installed power of the inverter can be fully utilized because no reactive power has to be delivered. This applies to non-salient synchronous machines with rotor excitation windings, because the rotor field excitation has to be controlled.

Operation of permanent magnet synchronous machines

The ability to change the excitation, i.e. the back emf voltage, is not available in permanent magnet synchronous machines. Consequently, the back emf voltage u_i is proportional to rotor speed: $u_i \sim \text{speed}$.

Therefore, permanent magnet synchronous machines (PMSM) cannot be operated simultaneously with constant stator flux, maximum torque per ampere or maximum active power.

Active power operation i.e. $\cos\varphi = 1$, is rarely used in PMSMs without excitation windings, because maximum torque cannot be reached.

Operation at maximum torque per ampere

To fully utilize the capabilities of the PMSM, a control algorithm which maximizes torque per ampere is mostly used. In this control, the maximum torque for a given back emf voltage is produced. A disadvantage of this control is the fact that the power factor $\cos\varphi$ is reduced because the stator flux linkage increases.



Below base speed the stator current is controlled to remain in phase with the back emf. As a result, for a given excitation, determined by the permanent magnets, the highest torque for the least amount of current is produced.

When speed increases, the inverter fed PMSM reaches its voltage limit at base (rated) speed. Further increase of speed is only possible when the field (from the permanent magnet) is reduced. This can be realized by phase shifting the stator current such that a negative d-component of current is produced. This d-component current (so called flux producing component) reduces the total excitation field in the machine and, hence, the back emf. At higher speeds, it is necessary to phase shift the stator current such that the stator voltage remains constant. Depending on the stator current and speed, different power factors ($\cos\varphi$) are obtained. The power converter has to be designed for the worst case $\cos\varphi$ at maximum speed.

Short-circuit operation

An important characteristic of PMSMs is the fact that at non-zero speeds a non-zero back emf voltage is induced in the stator windings by the permanent magnets. This effect can be utilized as an emergency brake to slow down the machine by short-circuiting the stator windings. On the other hand, this short circuit current may overload the converter or even destroy power devices when short circuit ratings are not taken into account. The short circuit current value depends on the permanent magnet flux linkage, as well as the stator resistance and stator inductance and to a certain extent on the machine speed. The short circuit current reaches a limit at higher speeds (Figure 22). The inverter should be designed for this current to avoid failure. It should be pointed out that this short circuit current sometimes is lower than the rated current of the machine. Furthermore, the short circuit torque is proportional to the squared flux linkage divided by the stator inductance (Figure 22).

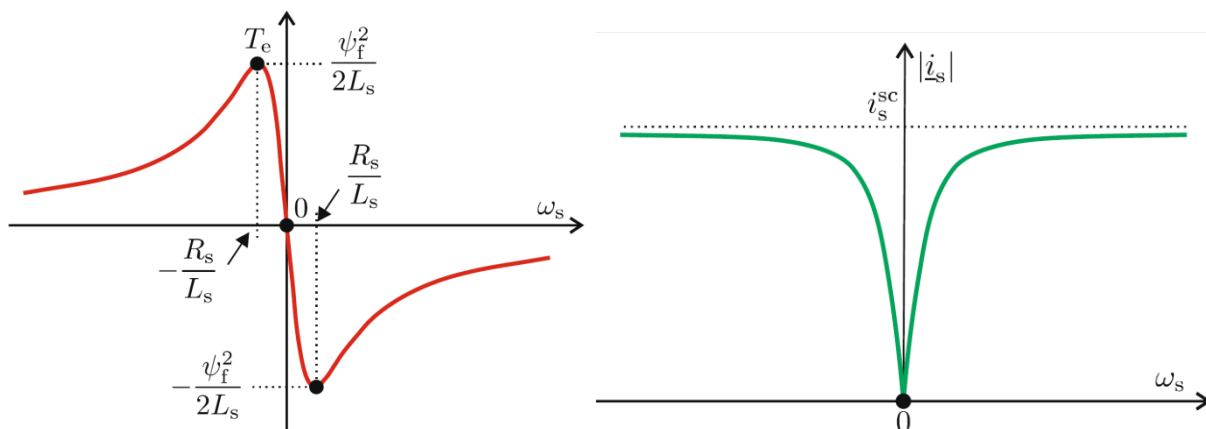

Figure 22: Short circuit torque and current compared to rotor speed (6)



Field weakening region

In addition to short circuit operation, a converter designer has to consider proper design of the converter for flux weakening. To reduce the field in the d-axis of the machine, the inverter has to inject a negative d-component.

However, if this excitation drops out, e.g. due to a forced inverter shut down, then a very large excitation voltage (back emf) could lead to destruction of inverter diodes or capacitors in a voltage source inverter, because the magnetic flux in the machine suddenly becomes much higher than before.

Trapezoidal control

Also known as 6-step control, this is the simplest algorithm. For each of the 6 commutation steps (in a 3 phase machine), a current path is formed between a pair of windings, leaving the third winding disconnected. This method generates high torque ripple, leading to vibration, noise and poorer performance compared to other algorithms.

Voltage-over-frequency control

Also known as voltage-over-frequency commutation, sinusoidal control overcomes many of the issues involved with trapezoidal control by supplying smoothly (sinusoidal) varying current to the 3 windings, thus reducing the torque ripple and offering a smooth rotation. However, these time-varying currents are often controlled using basic PI regulators, which lead to poor performance at higher speeds.

Field orientated control (FOC) for PMSM

Also known as vector control, FOC provides better efficiency at higher speeds than sinusoidal control. It also guarantees optimized efficiency even during transient operation by perfectly maintaining the stator and rotor fluxes. FOC also gives better performance on dynamic load changes when compared to all other techniques.

Similarly to induction machines, PMSMs can be operated in field oriented control (FOC), allowing a decoupling of the torque and flux producing stator current components. As a result, the d-current component of the stator current can be considered as the flux producing component, while the q-component is torque producing. In the base speed region, this d-component is usually set to zero to minimize stator losses and inverter current ratings. In the flux weakening region of PMSMs, a negative d-component is necessary to reduce the field in the machine.

When using FOC torque ripple is minimized and accurate motor control can be achieved at low and high speeds.



For field oriented control the rotor position has to be known, resulting in either an absolute encoder, mounted on the rotor shaft or by using sensorless control algorithms which measure the back emf voltage to determine the rotor position.

Today, synchronous servo drives are usually fed by a PWM voltage source inverter. The DC voltage source is converted by the inverter into a variable three-phase ac voltage. Both voltage and frequency can be controlled. When the synchronous machine has a field excitation winding an excitation chopper can be used to regulate field current. A simple step down converter connected to the DC link can be used.

Notable Features and Ratings

- PMSMs are being used extensively in low power (0,1kW to 10kW) servo applications in automation systems, robots machine and tools.
- PMSMs up to 30-250kW are increasingly being used in hybrid and full electric vehicles as propulsion drives.
- Electrically excited synchronous machines and PMSMs are and have been used in high-speed trains. However, as a cheaper alternative induction machines are also common.
- PMSMs are used, where efficiency and weight has the highest priority, such as in the aerospace industry.
- The PMSM drive offers the advantage of low rotor losses and is attractive in those applications where rotor cooling is expensive.

Strengths / Weaknesses

- Highest efficiency in base speed operation
- Highest torque/weight ratio
- The type of magnetic material used has a large effect on the overall machine price
- Additional current is necessary for field weakening range, which usually leads to a lower efficiency at high speeds (compared to induction machine)

Predominant Applications

- High efficiency drives (aerospace, automotive industry)
- Some household applications with low cost ferrite magnets
- Especially IPMSMs with concentrated windings, due to the reduced manufacturing complexity and cost, have become more popular in industry. Using concentrated windings, however, reduces the performance capability compared to a synchronous machine with distributed windings.

Synchronous Reluctance Machine (SynRM)

The Synchronous Reluctance Machine (SynRM) is a type of interior permanent magnet machine, without permanent magnets. Therefore, the rotor has a salient structure similar to the IPMSM without the flux created by the permanent magnets (Figure 23). Thus, the machine only generates reluctance torque and does not use the Lorentz force. Furthermore, the machine characteristics strongly depend on the rotor design and how the flux barriers are placed within the rotor. The goal of the flux barriers, which usually consist of air, is to create a high L_d/L_q inductance ratio (which is a measure of how good the machine is at field weakening) and L_d-L_q (which is a measure of how much torque the machine can produce).

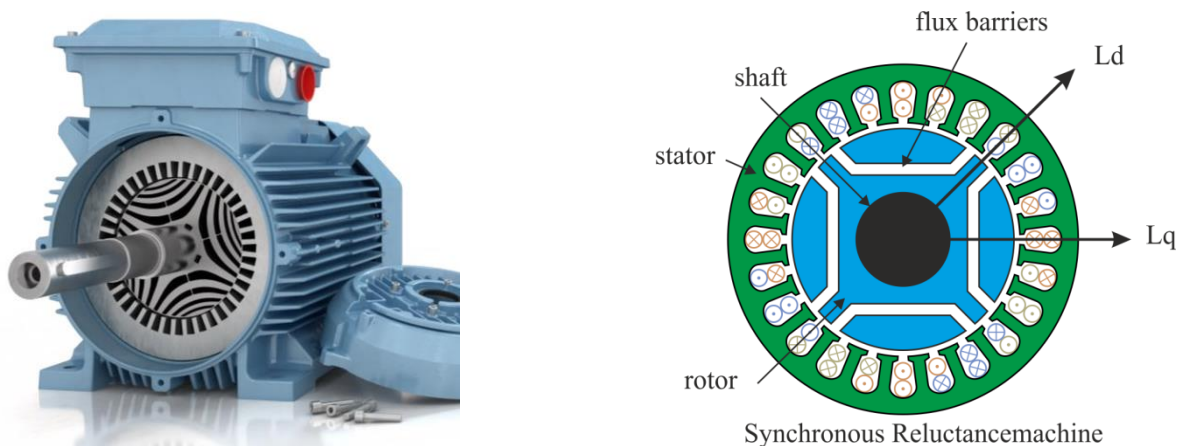

Figure 23: Cross section of a synchronous reluctance machine by ABB (16) (left), and a cross section (6) (right)

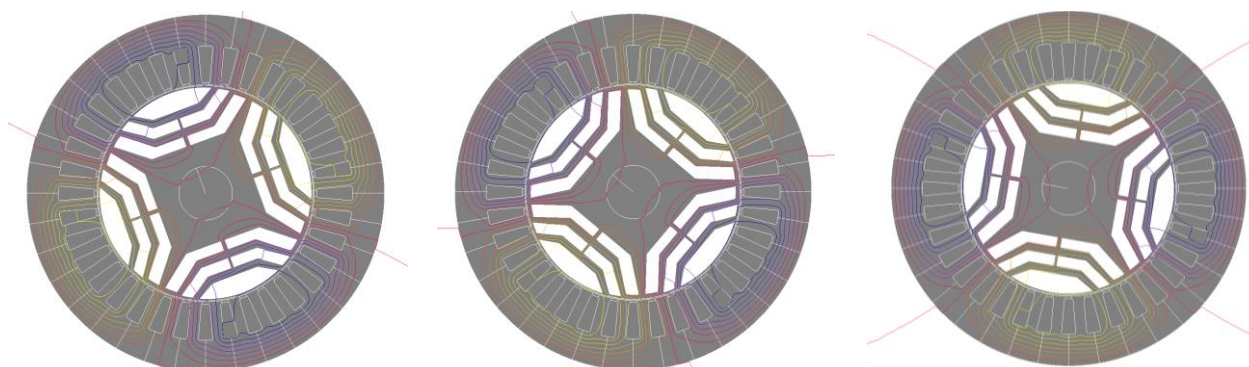

Figure 24: Magnetic flux paths within the synchronous reluctance machine with anti-clockwise rotation (4)



The SynRM is operated from the same converters used for synchronous- and induction machines. Furthermore, the same control algorithms can be applied, as with the salient PMSM.

In comparison to PMSMs, the power density of the SynRM is lower. In comparison to induction machines it is higher. Because the SynRM has lower losses (negligible rotor losses, see Figure 25) compared to the induction machine, it needs less cooling and therefore, can be built smaller.

Strengths / Weaknesses

- The synchronous reluctance machine has a higher efficiency than induction machines in base speed operation due to negligible rotor losses (Figure 25).
- Due to lower rotor losses, the rotor temperature of the synchronous reluctance machine is lower compared to induction machines. The lower temperature can furthermore lead to a smaller build volume of the machine.
- In contrast to induction machines and interior permanent magnet machines the SynRM has a very low ratio between base speed and maximum speed. Therefore, the machine has a limited region of constant power.
- Synchronous reluctance machines are good for applications which operate in a single operating point, such as pumps and fans.
- A benefit of the machine is its low rotor inertia, due to no magnets or rotor windings.
- The SynRM has a lower power factor ($\cos\varphi$) compared to a PMSM resulting in the necessity of an over dimensioned inverter.

Predominant Applications

- Compared to the other machine types this machine is quite new to the industrial market and therefore is not yet as established.
- ABB is substituting their induction machines with synchronous reluctance machines mainly for pump applications, due to their higher efficiency (Figure 25).

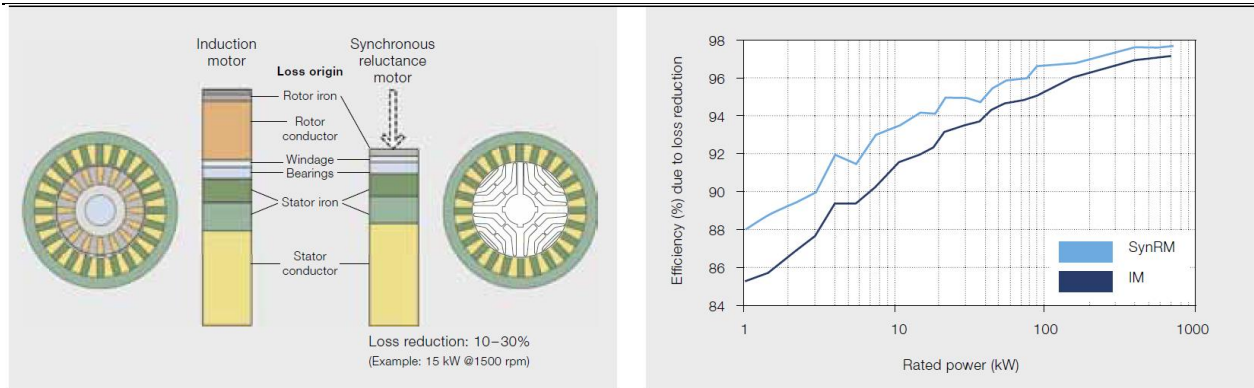

Figure 25: Comparison of a synchronous reluctance machine and an induction machine by ABB (16)

DC Machine

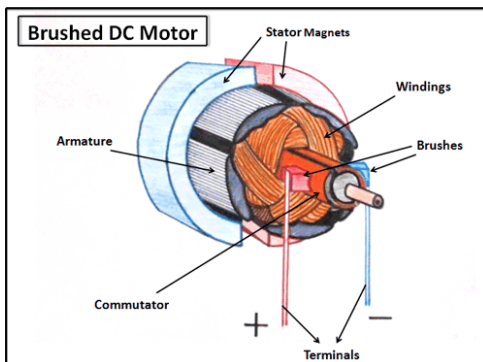

Figure 26: Stator and rotor of a permanent magnet DC motor (17)

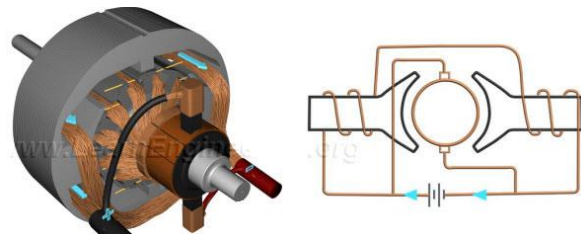

Figure 27: Stator and rotor of an externally excited DC motor and schematic of a parallel wound DC machine (1)

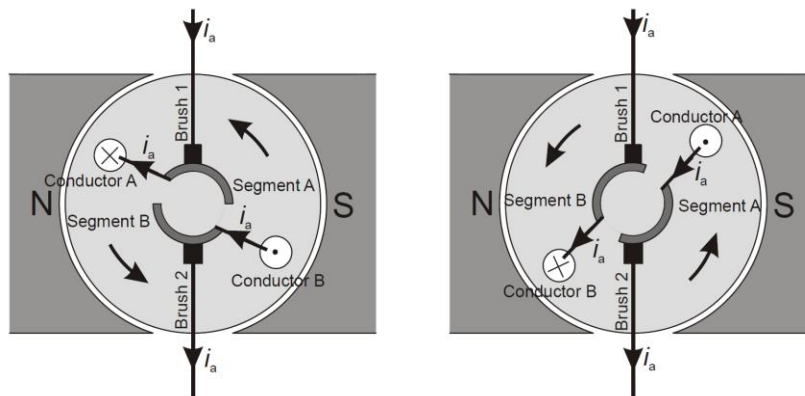

Figure 28: Cross section of a permanent magnet DC machine with two possible commutator positions (6)

Motor Structure and Functional Description

The above figures show different construction types of DC machines. Figure 26 shows permanent magnets on the stator, creating the excitation field of the machine. The rotor has rotor windings. These windings are fed by DC voltage via the commutator and brushes. Figure 27 shows a cross section of a DC machine. This image shows how the brushes contact the commutator and how the rotor field changes its direction depending on which brush contacts which commutator segment. Therefore, when the rotor turns the direction of the field of the rotor changes. As with each commutation voltage is switched mechanically onto a new set of windings (inductance) sparking can occur. Sparking is especially an issue for higher currents and at high speeds. Figure 27 shows a DC machine with excitation



windings on the stator instead of permanent magnets. This allows the excitation field to be regulated. The stator field can either be produced by magnets as shown in Figure 26, or by DC windings (Figure 18), generating the excitation field. The rotor of the machine is also called an "armature" and the rotor current therefore is called armature current. Due to the structure of DC motors, the excitation field and the armature field are orthogonal to each other. If both fields are independently adjustable such as in separately excited DC machines, independent torque and flux control can be readily applied to DC machines.

The rotor of the DC machine has a current carrying conductor in which a magnetic field is produced. In order to feed the armature current into the rotating rotor, brushes are needed. Brushes are small carbon blocks which are pressed by a spring against the commutator (copper contact area) of the rotating rotor. The commutator changes the direction of the armature current during the rotation (see Figure 29), so that the armature field is always orthogonal to the excitation field (see Lexicon for torque production).

To reduce the sparking at the brushes, compensation windings can be used in large DC machines as shown in Figure 29. These windings are situated near the North (N) and South (S) poles of the stator. Their task is to reduce the stator field at the commutation pole, therefore reducing the sparking, when the brushes commute. As the main stator field is dependent on the armature current amplitude and direction, the armature current too is used in the compensation windings.

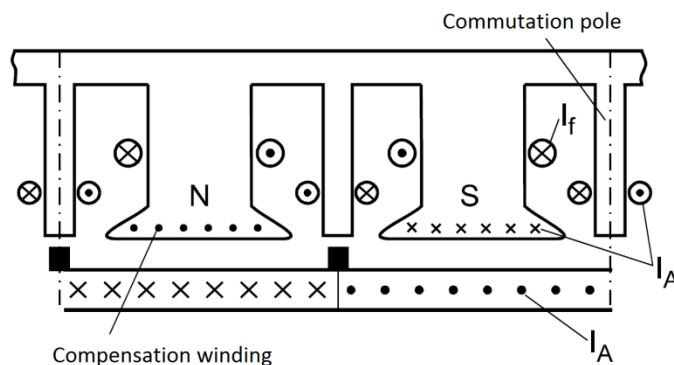

Figure 29: Compensation windings and commutation pole of a separately excited DC machine (4)



Brush life

“As an estimate, 7500 hours brush life could be considered normal for general purpose, medium horsepower DC motors with good commutator film operating with commutator surface speeds in the range of 2500 to 4000 rpm. The minimum life might be 2000 to 5000 hours with 10000 hours being about maximum. It is not uncommon however, for motors with light or variable loads, such as machine tool motors, to have brush life that is less than 2000 hours. Brush life is even further reduced at higher commutator surface speeds. As a rule of thumb, brush life at 3600 rpm is half that at 1800rpm. Brush life is also affected by load.” (18) The direct connection between brush life and rotor speeds explains why brushed DC machines are most commonly found in lower speed (<10000rpm) applications.

Motor Characteristics and Motor Control

DC-motors can be separated into 3 types:

- Separately / externally excited
- Series wound
- Parallel wound DC machines.

Separately excited DC machine

An externally or separately excited DC machine consists of two electrical circuits: the armature circuit (left side) and the field circuit (right side) is depicted in the equivalent circuit diagram in Figure 30. The field circuit consists of a winding, which has an inductance L_F and an ohmic resistance R_F . A voltage is not induced in the field winding, since it does not move in a magnetic field. The armature circuit is represented by a coil with its corresponding resistance R_A and inductance L_A . In addition, a voltage source u_i is included in the equivalent circuit that represents the induced back emf voltage. U_i is directly proportional to the machine speed and describes the counter induced voltage due to the rotating rotor field (see Lexicon for back emf).

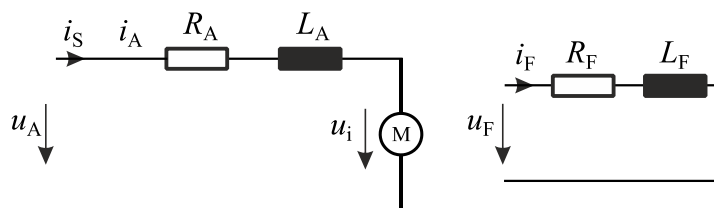

Figure 30: Separately excited DC machine (4)

This machine is widely used in servo drives because the excitation field and the armature current can be controlled independently.



When controlling the separately excited DC machine, normally, the flux is kept constant. The characteristic is, thus, a straight line with a negative slope which depends on the armature resistance R_A , as visible in Figure 31. With increasing R_A , the characteristic lines in Figure 31 become steeper. Hence, the speed drops faster with increasing torque. A good machine should have a small armature resistance so that a more rigid torque-speed characteristic is obtained.

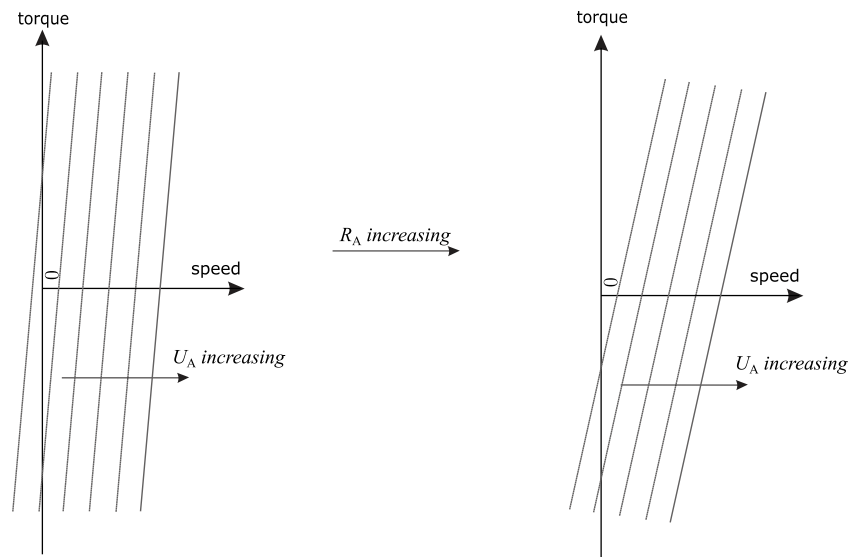

Figure 31: Torque-speed characteristic curves of a separately excited DC machine (4)

Speed control of separately excited DC machines

The speed of a separately excited DC machine can be varied, by either changing the terminal voltage of the armature U_A or by keeping U_A constant and changing an additional external resistor in the armature circuit or by changing the flux ϕ in the machine by controlling the field excitation voltage U_F . The *field excitation voltage* U_F can be regulated by using a separate electronic rectifier/ converter/ buck-chopper. Therefore, the flux in the machine is changed. The lower the flux, the higher the speed of the machine, however, again at a reduced torque level. The torque of the DC machine is directly proportional to the armature current I_A and the flux ϕ in the machine.

Speed can furthermore be controlled by changing the *armature voltage*, when there is a separate source supplying the field current. This method avoids disadvantages of poor speed regulation and low efficiency of armature-resistance control methods. Armature-resistance control adds additional resistances into the armature circuit to change the armature current. However, these resistances cause additional losses.



Series wound DC machine

If the field winding is connected in series with the armature winding, then a series wound machine is obtained (Figure 32).

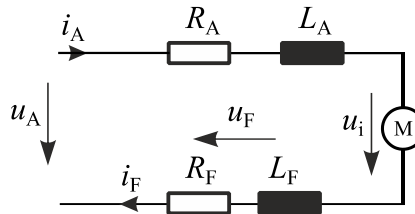

Figure 32: Series wound DC machine (4)

To determine the torque-speed characteristic of the series wound machine, one has to recognize that the flux in the machine is proportional to the armature current ($\Phi \sim I_F = I_A$). Additionally, it is assumed that no saturation in the machine occurs, which results in the following characteristic:

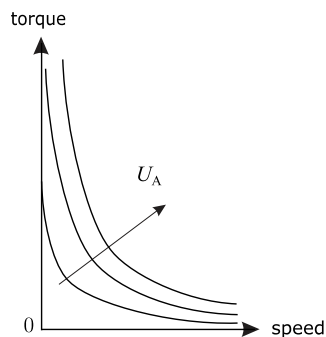

Figure 33: Torque-speed characteristic curve of the series wound machine (4)

The shape of this characteristic is very typical, therefore this kind of characteristic is frequently referred to as the series wound machine behavior. The machine produces its maximum torque at zero speed. When the machine accelerates its torque drops drastically with increasing speed. Series motors may not be operated without a load, as they will accelerate until over speed (mechanical destruction)! Whenever the machine is unloaded (Torque = 0), then the machine accelerates to very high speed (over speed). With series motors the speed is totally dependent on the load. The load is inversely proportional to the speed of the armature. If the load is high, the armature will rotate at a low speed.

The series-wound machine can also be operated with alternating current. When the armature current I_A changes direction, the field which is developed by I_A also changes similarly. Thus, the direction of the torque remains the same. However, eddy currents are induced in the iron of the machine by the alternating flux,



producing additional losses. Therefore, the flux conducting iron of such a machine must be made of thin lamination sheets which are isolated from each other.

Speed control of series DC machines

An easy method to control speed is by keeping the armature voltage constant and by changing the armature resistance. A disadvantage is the additional losses generated in the resistance. By adding a resistance the armature current decreases and thus the machine speed too decreases.

Another speed control method can be achieved by adjusting the armature voltage. This method is advantageous as no additional losses are generated in the resistance.

Shunt/ parallel wound machine

In a shunt wound DC machine, the field winding is connected in parallel to the armature circuit so that armature voltage U_A and excitation voltage U_F are equal. In shunt- and separately-excited motors, the field flux is nearly constant. Consequently, increased torque must be accompanied by a very nearly proportional increase in armature current and hence by a small decrease in back emf. Since back emf is determined by flux and speed, the speed must drop slightly as visible in Figure 34.

Today, the shunt machine is rarely used in industrial applications. This machine type can be used where a constant speed is required and the starting torque does not have to be that high such as in fans, blowers or centrifugal pumps.

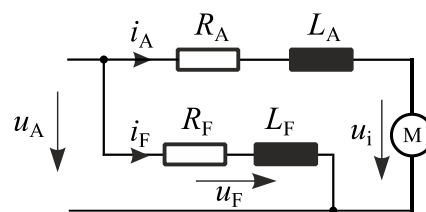

Figure 34: Parallel wound DC machine (4)

The torque-vs.-speed characteristic of a shunt wound DC machine is already shown in Figure 31. The characteristics are the same, because for the separately excited DC machine a constant flux is assumed at a certain armature voltage U_A . In the shunt wound machine this is always the case. With increasing speed the torque decreases.

The shunt wound motor has the ability to self-regulate its speed when the machine rotor is loaded. Unlike series motors, the speed of the shunt motor is independent of the shaft load. As the load to the motor increases, the speed of the motor slows



down instantaneously. Slowing down the speed reduces the back emf, which in turn increases the current in armature branch. This results in the increase of the motor speed. On the other hand, if load is decreased, then motor speed will rise instantaneously. This in turn will increase the back emf, thus reducing current to the motor. Gradually the motor will reduce its speed. As a result, the DC shunt motor is capable of maintaining a constant speed irrespective of load changes. Because of this feature the motor is used where fine precision of the motor speed is required (19). This can also be achieved with a separately excited DC machine, when the field flux is regulated to a constant value.

Speed control of shunt wound DC machines

In *field resistance control* speed variation is accomplished by means of a variable resistance inserted in series with the shunt field. An increase in the controlling resistance reduces the field current I_F which leads to a reduction in the flux and an increase in speed. This method of speed control is independent of load on the motor. Power wasted in controlling resistance lower compared to the controlling resistance in the armature path, as the field current is a small value compared to the armature current I_A .

The maximum speed is reached at the minimum value of flux, which also means that top speeds are only obtained at reduced torque.

In *armature resistance control* the armature circuit has an additional variable resistance. Field is directly connected across the supply (Figure 34) so flux is not changed due to variation of series resistance. This method is used in printing press, cranes, hoists where speeds lower than rated is used for a short period only due to the additional losses in the resistance (20).

Operating Limits of DC Machines

In the following, the steady state operating limits of the separately excited DC machine are considered. The separately excited DC machine can be operated in all four quadrants a suitable inverter is used (see Figure 38). In Figure 35 the continuous operation in the first quadrant (torque $T > 0$ and speed $n > 0$) can be seen. The armature resistance is neglected when discussing the electrical and mechanical quantities in this consideration. However, when discussing thermal limits of a machine, the winding resistance cannot be neglected, otherwise there would be no DC-losses due to the armature current. In the base speed range ($< n_N$), or the armature control range, the flux ϕ is kept constant at rated value ($k \cdot \phi = \text{const.}$, k is a machine specific constant), therefore torque is proportional to the armature current I_A and the induced voltage U_i is proportional to speed: Torque $\sim I_A$ and Speed $\sim U_i$. In base speed the thermal limit of the machine is $I_a = I_{a,N}$ which is the



nominal armature current and therefore the maximal current which also limits the nominal torque $T_N \sim I_{a,N} = \text{const}$. Below base speed, the armature current can be adjusted continuously up to its maximum rated value $I_{A,N}$. Hence, rated torque can be obtained in the whole base speed range. Accordingly, the armature voltage U_A increases linearly with speed similar to the induced voltage u_i .

Starting torque and maximum torque are limited by the armature current that can be successfully commutated.

The mechanical power P_m is proportional to the speed n and torque i.e. rises in base speed region linearly with speed (torque is constant at maximum value).

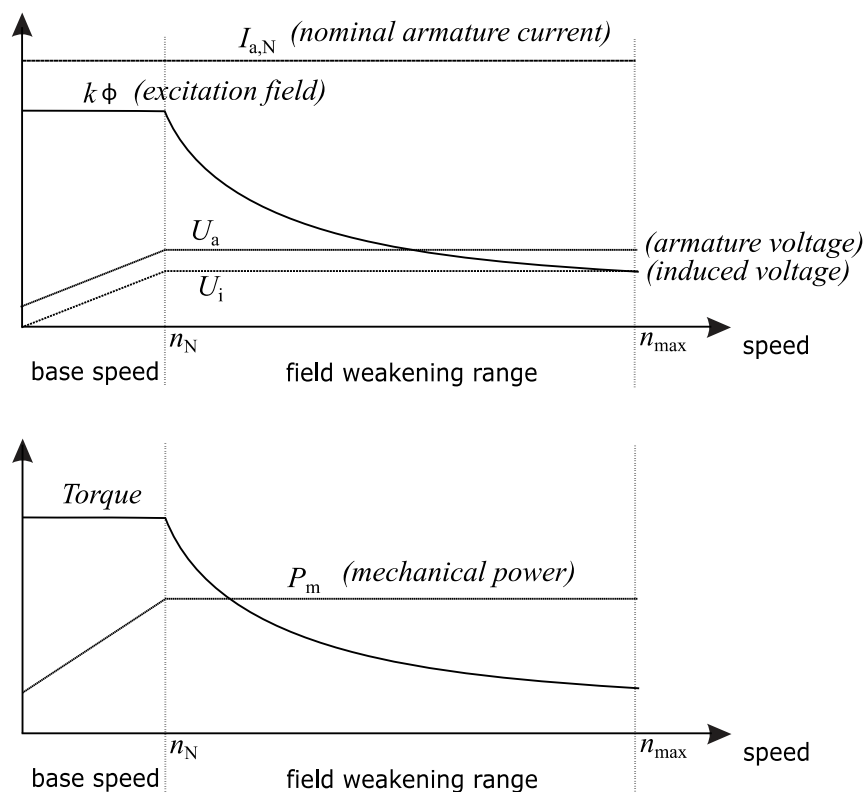

Figure 35: Operating limits of the separately excited DC machine (4)

The limit of the mechanical power can be calculated by: $P_{m,N} = T_N \cdot 2\pi \cdot n_N$. This is reached at nominal speed n_N . At nominal speed n_N the induced voltage u_i reaches the armature voltage U_A minus the voltage drop over the armature resistance as can be determined from the voltage loop from the equivalent circuit in Figure 30 i.e. $u_i \approx U_A - R_A \cdot i_A$. To further achieve higher speeds i.e. beyond rated speed, one has to reduce the field $k \cdot \phi$ (field weakening range). The substantial advantage of such a control principle is the possibility to increase the speed range for a given drive



configuration without over-sizing the machine and the converter. However, a field current regulator is necessary. Within field weakening range (speed $> n_N$) the machine can be operated at constant power P_m i.e. Torque reduces proportional to $1/\text{speed}$. In field weakening range the machine flux is reduced such that the induced voltage $U_{i,N}$, which is proportional to flux \cdot speed $U_i \sim \phi \cdot n$, and the armature voltage U_a are kept at their individual maximum values.

Operating the machine at even higher speeds (n_k) in combination with full rated current, can lead to an increased sparking under the brushes (incorrect commutation). In order to ensure good commutation at higher speeds, the excitation should not fall below a minimum value and the armature current must be reduced. To reach these high speeds, the armature current I_a has to be reduced, which allows the further increase of the induced voltage U_i up to the armature value U_a . The reduction of the armature current I_a in turn reduces the maximum machine torque and therefore also the mechanical power P_m .



Converter operated DC machines

In modern drives, the armature voltage is electronically controlled by converters or DC choppers. Using a buck chopper, the armature voltage can be adjusted from zero to DC link voltage U_B (source voltage). The application of positive armature voltage enables a positive speed of the DC machine, while the positive armature current I_a results in a positive torque i.e. first quadrant operation (positive torque (T) and positive speed (n) control as shown in Figure 36. If only a buck converter is used, the DC machine cannot operate in generator mode i.e. the current can only flow from the DC link U_B into the machine ($I_a > 0$), furthermore, the DC link voltage has to be larger than the armature voltage U_a . In Figure 36 the excitation field is controlled by a DC/DC converter enabling flux control if the excitation voltage U_f of the DC machine can be controlled. It is also possible to keep the field excitation constant and only control the armature voltage via the buck chopper.

If a boost chopper is used, the DC machine can only be operated as a generator (Figure 37). Here, the induced voltage U_i by the machine and thus the armature voltage U_a is larger than the DC link voltage U_B , allowing a current flow into the DC link U_B i.e. $I_a < 0$. This allows still positive speed values (as U_a is positive), however, the negative armature current results in a negative torque, which allows operation in the 4. quadrant (negative torque, positive speed).

Using a 4 quadrant converter (combination of buck- and boost-chopper) in the armature circuit, the DC machine can be controlled and operated in all four quadrants i.e. as a motor and generator as shown in Figure 38. The 4 quadrant converter allows positive and negative armature voltages allowing positive and negative machine speed, as well as positive and negative armature currents enabling the DC machine to produce positive and negative torque. In Figure 38 the field excitation is accomplished by using a buck converter. This allows the field current and thus the machine flux to be controlled. The excitation voltage here can only be positive.

If a separately excited DC machine is operated in a single phase AC network, the ac voltage can be rectified directly into a DC voltage as shown in Figure 39. Furthermore, here, the field excitation is rectified AC/DC and then controlled with a buck chopper, allowing flux and therefore also speed control in the DC machine.

Alternatively, to the previously discussed topology a DC machine can be operated in positive and negative direction with a buck chopper, if the field excitation current can be controlled positive and negative i.e. the flux in the machine can change its direction. This would need a DC/DC converter in Figure 36 in the excitation circuit which can produce a positive and negative excitation voltage U_F .

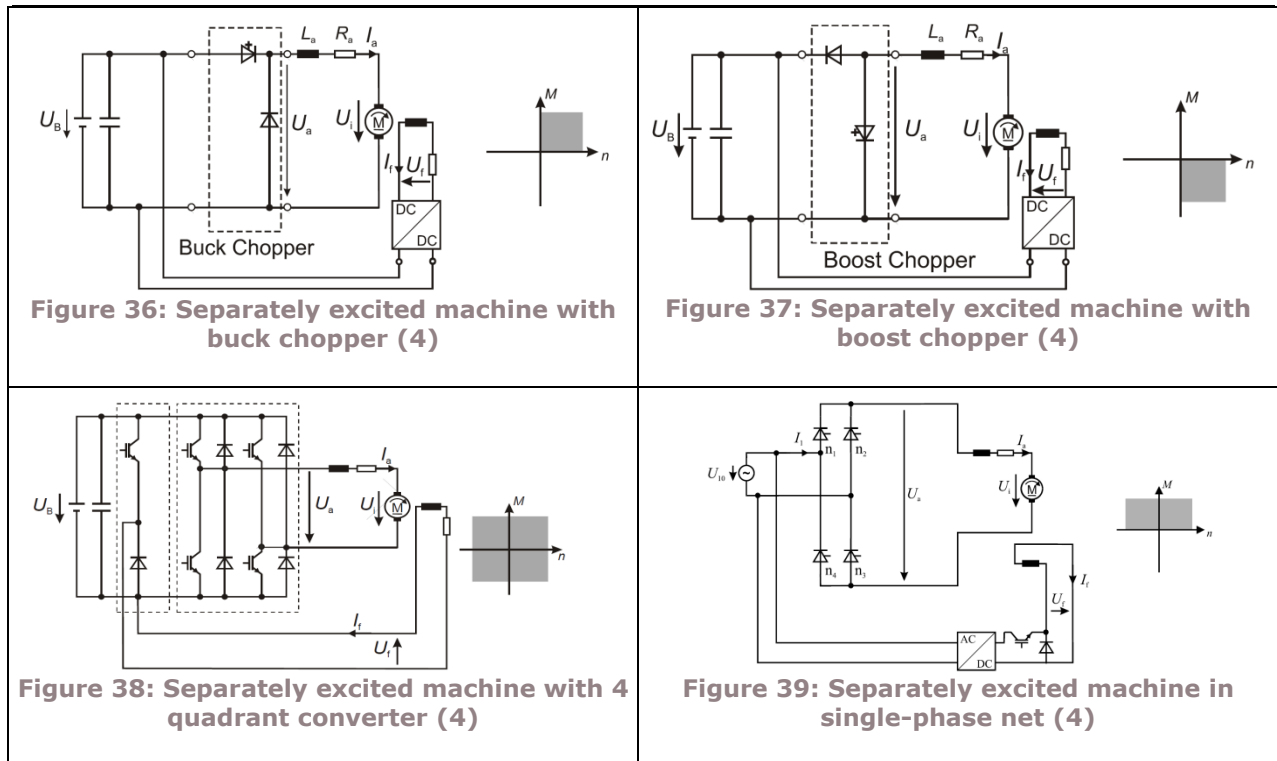

Notable Features and Ratings

- In the past, universal machines were applied for variable speed drive applications. Nowadays, DC machines are being replaced by induction drives, as induction machines are a cheap alternative and do not have slip rings and therefore reduced motor maintenance. Another benefit of induction machines is their commonly higher efficiency compared to DC machines, however, more power electronics is necessary to control the drive.
- DC machines are more common in the smaller power range i.e. domestic appliances <1kW, with speeds below 10000rpm. There are however small ~100W DC motors with higher speeds (~20000rpm)
- Permanent magnet excitation can be found in the low power machines <5kW.
- 1MW DC machines do exist, whereas the mass market of DC machines is found in the power range up to 10kW.



Strengths / Weaknesses

- The DC machine is very easily controllable i.e. low expenditure of power electronics and minimal need of microcontroller power.
- A weakness of this machine type is its increased maintenance demand and reduced lifetime due to the mechanical commutator i.e. the graphite brushes have to be replaced.
- The mechanical commutation can furthermore cause electromagnetic interference due to sparking.
- Because DC motors have mechanical brushes, they are used in environments with rather clean air, as not to cause cogging which increases the risk of brush/ commutation failure.
- Today, the various possibilities of digital logic (complex controls) and declining prices of semiconductor devices are responsible for the replacement of conventional DC machines by constant low-maintenance machine types i.e. induction and synchronous machines.

Predominant Applications

A large number of DC machines are produced in the form of universal motors (series wound machine), because it can be simply and economically operated in single phase grids. The series DC motor is used where high starting torque is required, and variations in speed are possible. The universal machine (series DC motor) is used in many single phase AC household appliances, such as washing machines, mixers, vacuum cleaners and in hand-held power tools. They are also found in industrial equipment i.e. air compressors, traction systems (fork lifts). Often used in appliances which are only used intermittently i.e. food mixer, power tools.

The separately excited DC machine is still used especially as a position control drive in low power servo applications because the excitation field and armature current can be controlled independently. As well as for applications with higher starting torque and fairly constant speed, for example conveyors, elevators, rolling mills. However, due to efficiency and reduced motor maintenance many of the DC machines are being replaced by variable speed AC drives (mainly induction machines).

The shunt wound motors can be used where constant speed is required and starting conditions are not severe. Applications are for example fans, lifts, cranes, centrifugal pumps.



Brushless DC Machine (BLDC / electronically commutated motor)

The commutator helps in achieving unidirectional torque in a conventional DC machine. In BLDC machines the rotor consists of permanent magnets, while the stator is wound with a specific number of poles. Often BLDC motors are produced as outer rotor types machines, as shown in Figure 41. The inner rotor schematic with windings on each pole is shown in Figure 40. The essential difference to the conventional DC machine is that the commutation is performed electronically with a controller rather than mechanically with brushes. The windings are connected to a control circuit, which energizes the windings such that a rotating field is generated. The rotor magnet tries to align with the stator field producing torque and thus movement (21).

The BLDC machine structure is essentially a permanent magnet synchronous machine (PMSM) with concentrated windings. Commonly the machine is also known as a PMSM with surface mounted magnets and concentrated windings; however, in some industries the term BLDC is more established.

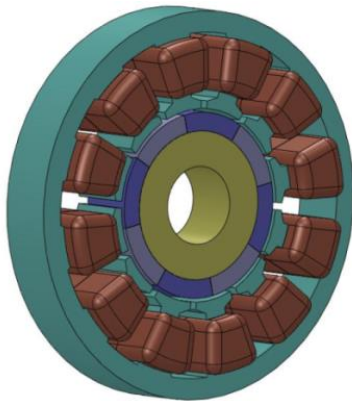

Figure 40: Internal rotor BLDC motor schematic (22)



Figure 41: Stator (left) and outer rotor (right) BLDC (23)



Motor Characteristics and Motor Control

“The advantage of internal rotor motors (Figure 40) lie in their low rotor inertia and the superior dissipation of lost heat. By contrast, with external rotor motors, the heat-generating coils are insulated against their environment by the rotor housing and magnets (Figure 41). External rotor motors display their advantages in mass-produced applications, because they can be more inexpensively produced. They can also be made shorter and usually have lower standstill torque (holding torque), as well as a higher torque thanks to the larger rotor diameter, at the same magnetic force” (23)

Generally speaking, all control algorithms designed for synchronous machines with concentrated windings can be applied to BLDC motors. In the following the most common are mentioned.

Trapezoidal control/ Block commutation

Also known as 6-step control, trapezoidal control is the simplest algorithm. For each of the 6 commutation steps (in a 3 phase machine), a current path is formed between a pair of windings, leaving the third winding disconnected. This method generates high torque ripple, leading to vibration, noise and poorer performance compared to other algorithms.



In contrast to common synchronous machines (which are controlled with sine wave voltages), traditionally BLDC motors are controlled with a block shaped voltage (trapezoidal shaped current). In Figure 42 a control schematic is shown. The 3 phase BLDC motor has three hall sensors (H1 to H3), which act as the position sensors and in case of a BLDC motor also as the switching signals (In Figure 42 the values Hall1, Hall2 and Hall3). As soon as the rotor passes the hall sensor, the controller switches the DC voltage to the next phase (A, B or C). Therefore, no complicated controller or control algorithm is necessary. As shown in Figure 42 the voltage has a rectangular shape. This rectangular voltage shape results in a trapezoidal current and back emf shape in the machine.

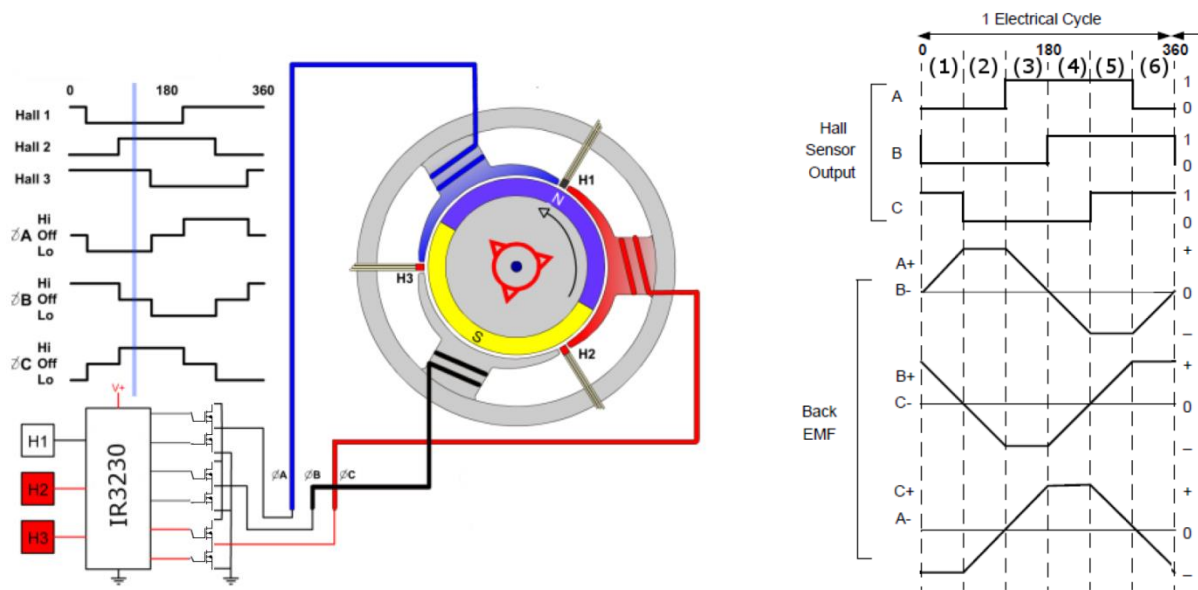

Figure 42: Control of a BLDC motor with Hall sensors (left), exemplary hall sensor output and back emf waveforms (right) (24)

The disadvantage of block commutation is that due to the discrete switching between the phases, the stator and rotor field are not always perpendicular to each other. This results in a lower torque than would be achievable with another control. Furthermore, block commutation causes a torque ripple with six times (in 3 phase machines) the frequency of the electrical rotary frequency of the motor. This leads to vibrations and noise. Especially at low speeds the motor will not rotate uniformly. This is why block commutation is not suitable for slow turning (less than 10% of nominal speed n_N) applications.

Sinusoidal control

Also known as voltage-over-frequency commutation, sinusoidal control overcomes many of the issues involved with trapezoidal control by supplying smoothly



(sinusoidal) varying current to the 3 windings, thus reducing the torque ripple and offering a smooth rotation. However, these time-varying currents are controlled using basic PI regulators, which lead to poor performance at higher speeds.

“The optimum form of energization is the sinusoidal commutation, whereby each winding of the motor is powered with a sine wave shifted by 120° , resulting in a continuously rotating stator magnetic field with constrain strength. In case of load changes between two hall sensors, the sine wave cannot be adjusted, however, resulting in incorrect positioning of the magnetic field. This can only be corrected with the next hall sensor signal. The sinusoidal commutation therefore ideally requires a higher resolution system for determining the rotor position. Normally, this consists of an optical or magnetic encoder that determines the position of the rotor with sufficient precision at all times and correspondingly adjusts the current.” (23)

Field orientated control (FOC)

Also known as vector control, FOC provides better efficiency at higher speeds than sinusoidal control. It also guarantees optimized efficiency even during transient operation by perfectly maintaining the stator and rotor fluxes. FOC also gives better performance on dynamic load changes when compared to all other techniques. (for more information see Synchronous Machines control chapter)

Sensorless control

Instead of using hall sensors in the stator (or encoders on the rotor), the back emf can be measured and used to determine the rotor position and therefore the switching signals of all phases. How the output of the hall sensors and the back emf match is shown in Figure 42 on the right. It is clear that the switching position can be determined when the back emf is known. This type of sensorless control is quite simple. A more sophisticated method to determine the rotor position is possible whereby for example current is measured. The core of this type of system is a precise motor model, which is used in parallel to the real motor and calculates the expected control values. The expected control values are then compared to measured quantities. “The result is a “virtual encoder” that delivers the position and speed information, beginning at a certain minimum speed, with the same precision as an actual optical or magnetic encoder.” (23)

“What both sensorless methods have in common, is that no information on the rotor position is available when idle, thus a special startup method is required. Similar to a stepper motor, the motor is operated in a controlled mode for several commutation cycles until it has attained the required speed and the sensorless measurement can determine a rotor position.” (23)



Strengths / Weaknesses

- Higher efficiency compared to brushed DC machines.
- Longer lifespan, lower maintenance, no sparking issues with the mechanical commutator.
- Higher cost and more complex circuitry as an additional controller is required.
- Higher torque per weight than conventional DC machines.

Predominant Applications

- CPU cooling fans, CD/DVD players, scale models.
- Predominantly used in lower power (<20kW) applications.

Switched Reluctance Motor (SRM)

A Switched Reluctance Motor (SRM) is a cost-efficient motor without rare-earth materials.

Motor Structure and Functional Description



Figure 43: A 3 phase, 2 pole pair, 12-8 SRM (25)

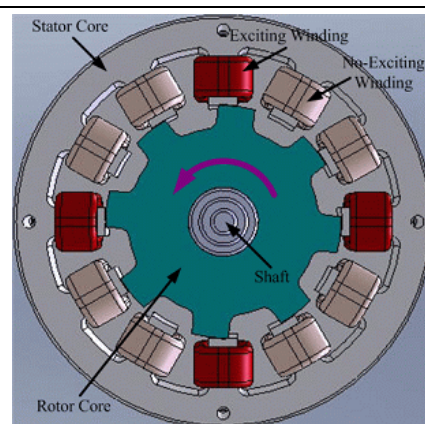

Figure 44: Rotation caused by reluctance force (26)

SRMs have a very simple structure as shown in Figure 43. Both the stator and the rotor have salient poles. There is no magnet in a SRM. Concentrated winding are usually used for the stator. The relationship between the number of the stator teeth N_s , the magnetic pole pair number p and the number of the electrical phases N_{ph} for SRMs is written as

$$N_s = 2pN_{ph}$$

To avoid equilibrium positions in which the SRM cannot provide torque, the number of the rotor teeth N_r must be different from N_s . Typically, N_r is calculated using

$$N_r = 2p(N_{ph} - 1)$$

The following table provides some indication of the machine configurations in use.



Phase number	1		2		3			4		5	
S rotor teeth number	2	4	4	8	6	12	18	8	16	10	20
Rotor teeth number	2	4	2	4	4	8	12	6	12	8	16
Number of pole pairs	1	2	1	2	1	2	3	1	2	1	2

Table 4: Typical SRM machine configuration (6)

SRMs with higher phase numbers are rare, since this will increase the number of switches needed in the converter. A limiting factor for higher teeth number is the machine diameter due to the space needed by the teeth. Hence, only SRMs with a large diameter are candidates for higher teeth number.

Unlike other types of motors, the torque production of SRMs is based on reluctance force, which is explained in the lexicon. In Figure 44, only the red coils are excited at a point in time. The rotor will be pulled towards the phase in red, which causes a counterclockwise rotation of the rotor. It does not matter in which direction the current flows, since the production of the reluctance torque is independent on the direction of the flux. A continual excitation of different phases leads to a continuous rotation, which is shown in Figure 45.

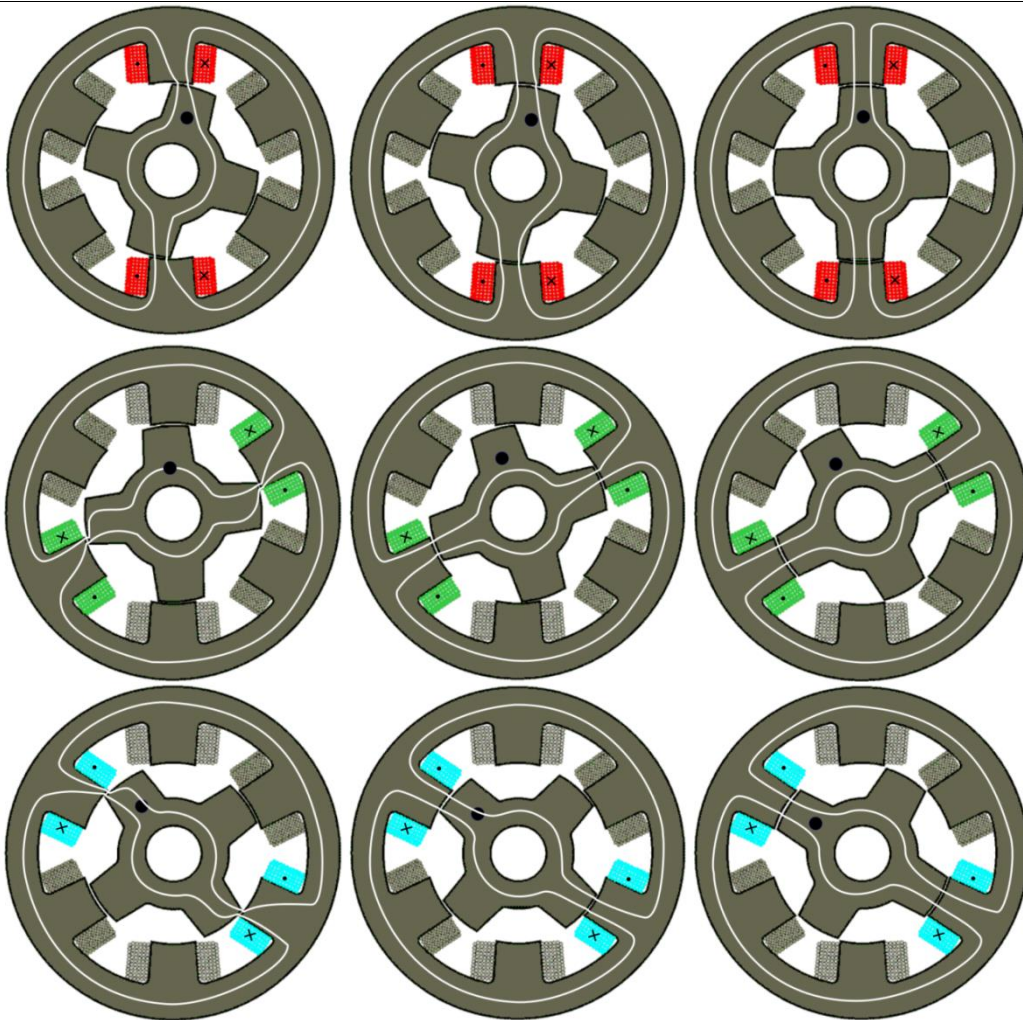

Figure 45: Continuous rotation of switched reluctance motors (4)

Motor Characteristics and Motor Control

Torque-Speed Characteristics

The SRM can be operated as a stepper motor, which is explained in the chapter Stepper Motor. For traction applications, the current hysteresis control is used for low speed and the single pulse control is used for high speed. Both control strategies will be introduced later. The torque/power over speed curve can be found in Figure 46. It is very similar to other kinds of motors. Below the base speed, maximum torque is given by the current limit of the winding. Beyond the base speed, voltage becomes the limiting factor due to the high back emf.

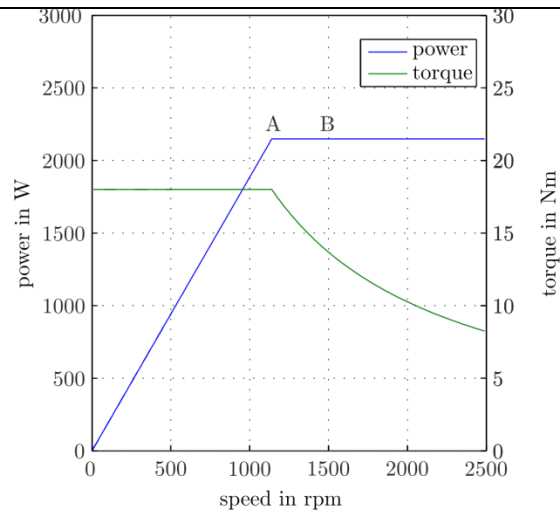

Figure 46: Torque and power over speed curve of a SRM (6)

Equivalent Circuit

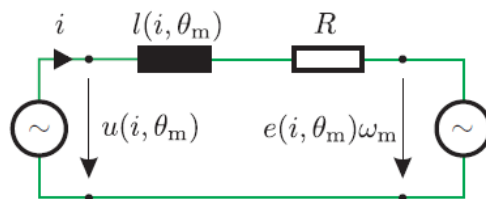

Figure 47: Equivalent circuit of one phase of a switched reluctance machine (6)

The single-phase equivalent circuit of an SR motor is represented by a series circuit (Figure 47), which consists of an inductance $l(i, \theta_m)$, a stator winding resistance R and a voltage source $e(i, \theta_m)\omega_m$ which is proportional to speed (back emf). It is noted that the inductance is a strong non-linear function of rotor position θ_m and stator current i . Therefore, the accurate value of the inductance can only be calculated using finite element method or measured on the test bench. The voltage $u(i, \theta_m)$ changes due to the switching of the power modules. The sequence of the switching is usually determined depending on the rotor position and stator current, which will be further explained in the control strategy – Current Hysteresis Control.



Converter Topology

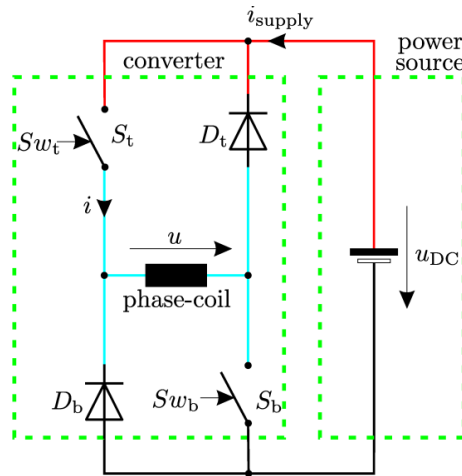

Figure 48: SR drive with asymmetric half-bridge converter topology (6)

A commonly used converter for switched reluctance drive utilizes two switches per phase. This topology is referred to as an asymmetrical half-bridge converter (Figure 48). The drive has three basic modes of operation, which are shown in Table 5. The value '1' in the table means that the switch or the diode is conducting.

	S_t	S_b	D_t	D_b	u
Mode 1:	1	1	0	0	u_{DC}
Mode 2:	1	0	1	0	0
Mode 2:	0	1	0	1	0
Mode 3:	0	0	1	1	$-u_{DC}$ for $i > 0$

Table 5: Switching states and resulting phase voltage of asymmetrical half-bridge (6)



- Mode 1, magnetization state: both switches S_b and S_t are closed, while the diodes D_b and D_t remain non-conducting. The phase voltage u is equal to the supply voltage u_{DC} and the supply current i_{supply} is equal to the phase current i . Energy from the supply source is transferred to the load and to the magnetic energy reservoir stored in the inductance.

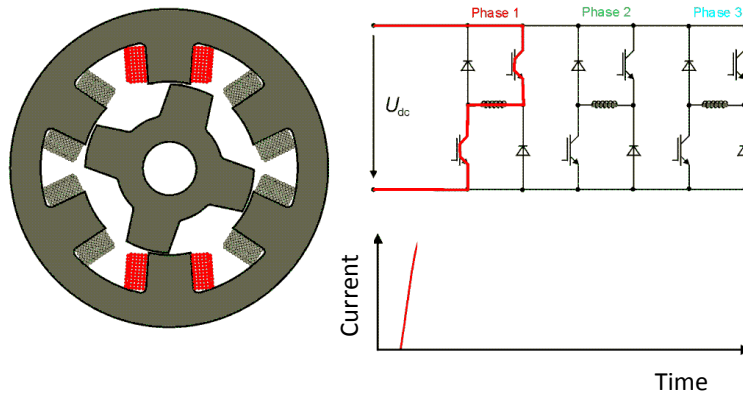

Figure 49: Current flow of the magnetization state (4)

- Mode 2, free-wheeling state: switch S_b is closed and S_t is open. The diode D_b is conducting and D_t is non-conducting (or vice versa, i.e., there are two free-wheeling states). The phase voltage u is equal to zero and the supply current i_{supply} is also zero. The supply source is disconnected from the machine. Thus the energy stored in the magnetic field is transferred to the load. Therefore the torque production continues. The two variations of free-wheeling state are usually used in turn to balance the thermal stress of modules.

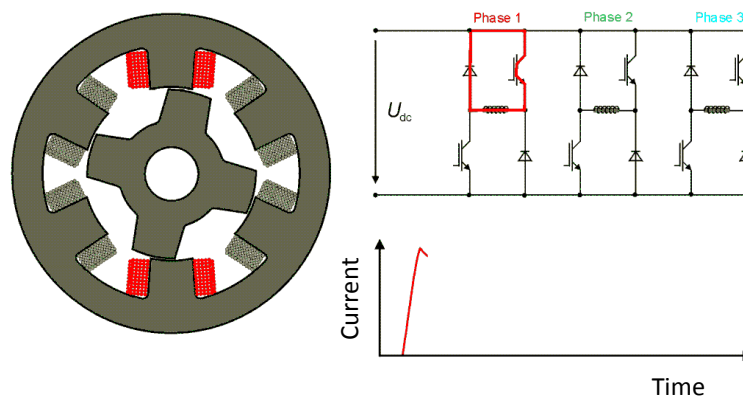

Figure 50: Current flow of the free-wheeling state (4)



- Mode 3, de-magnetization state: both switches S_b and S_t are open, while the diodes D_b and D_t are conducting. The phase voltage u is equal to u_{DC} and the supply current i_{supply} is equal to i . This mode of operation can only persist for as long as the phase current is greater or equal to zero. Energy from the magnetic reservoir is transferred to the load as well as the supply.

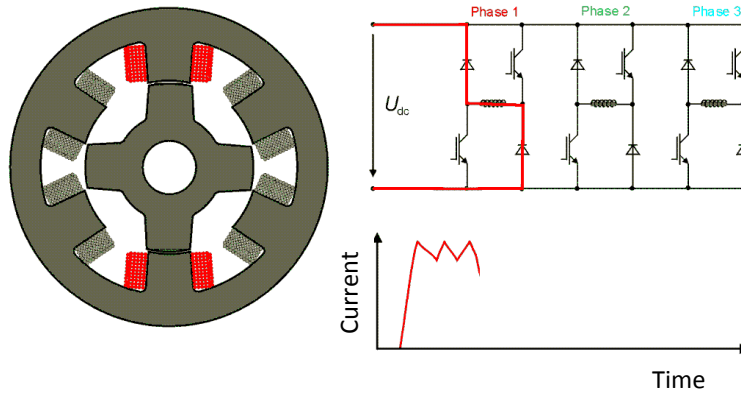

Figure 51: Current flow of the de-magnetization state (4)

Rotor Position

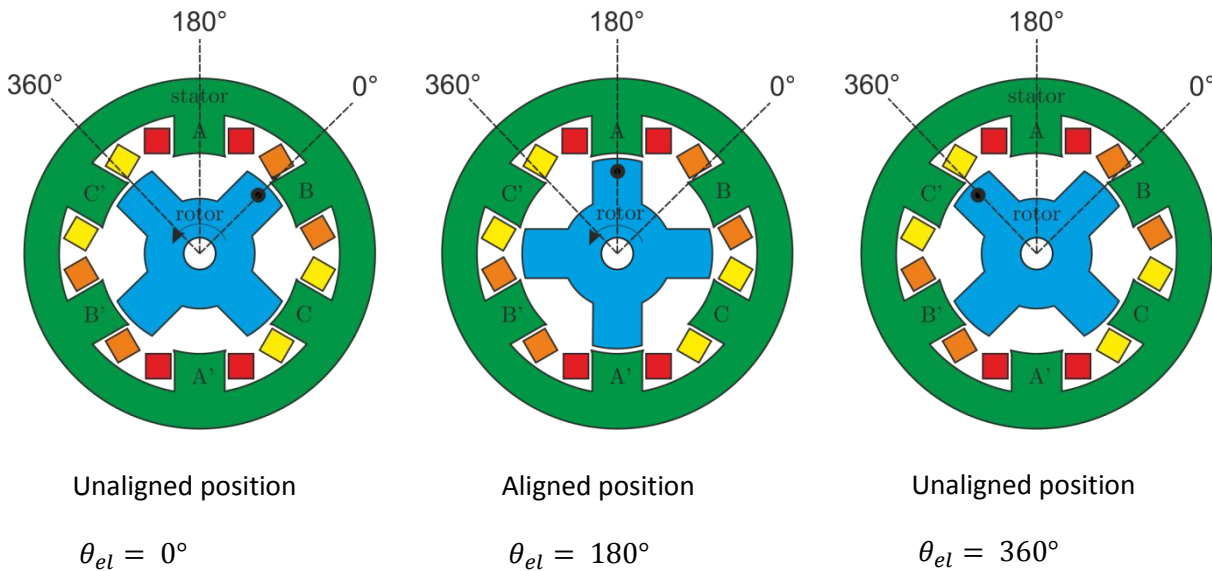

Figure 52: Electrical cycle for phase A (6)

As shown in Figure 52, one electrical period (360 electrical degrees) for phase A is defined as the movement of the rotor from unaligned rotor position (left part of the figure) across the aligned position (middle part) to the next unaligned position (right part) again. Unaligned rotor position for phase A is defined as the position with maximal air gap, which means at this position the magnetic reluctance is maximal



and inductance is minimal. In contrast, at aligned rotor position, the magnetic reluctance of phase A reaches its minimum and the inductance reaches its maximum. This electrical cycle repeats four times in a mechanical revolution for SRMs with four rotor teeth. The ratio between electrical angle θ_{el} and mechanical angle θ_m is defined as:

$$\theta_{el} = N_r \times \theta_m$$

Current Hysteresis Control

At low speed, the SRM is operated using the current hysteresis control. An accurate rotor position measurement is necessary. The phase is turned on at a certain electrical angle, the turn-on angle θ_{on} . After the current reaches its reference value i_{ref} , the mode 1 and mode 2 of the asymmetrical half bridge are applied to keep the current inside a hysteresis band $\pm\Delta i$. At a certain electrical angle, the turn-off angle θ_{off} , the mode 3 is applied so that the current decreases to zero. An example of the phase voltage, back emf, phase current as well as the torque is shown in Figure 53.

In order to achieve the maximal efficiency, the determination of the optimum control parameters θ_{on} , θ_{off} , i_{ref} for each operating point is done using analytical simulation or finite element method and then fine-tuned on the test bench. The hysteresis band $\pm\Delta i$ is a trade-off between the control accuracy and switching losses. Depending on the current rating of the motor, the phase current can reach several hundred amperes. The hysteresis band Δi is often one magnitude smaller than the reference current i_{ref} . The slope of the current at the free-wheeling state depends mainly on the back emf, which is proportional to the rate of change of the phase inductance.

$$\frac{di}{dt} \sim e(i, \theta_m) \sim \frac{\partial l(i, \theta_m)}{\partial \theta_m}$$

This is a function of the rotor position and it reaches its maximum at around the middle of the excitation period. Therefore the current drops the most quickly at around the 0.035 second to the 0.04 second.

During magnetization state, the back emf play a minor role at the low speed region compared with the phase voltage $u(i, \theta_m)$. The slope of the current is mainly inversely proportional to the phase inductance, which reaches its maximum at the aligned position.

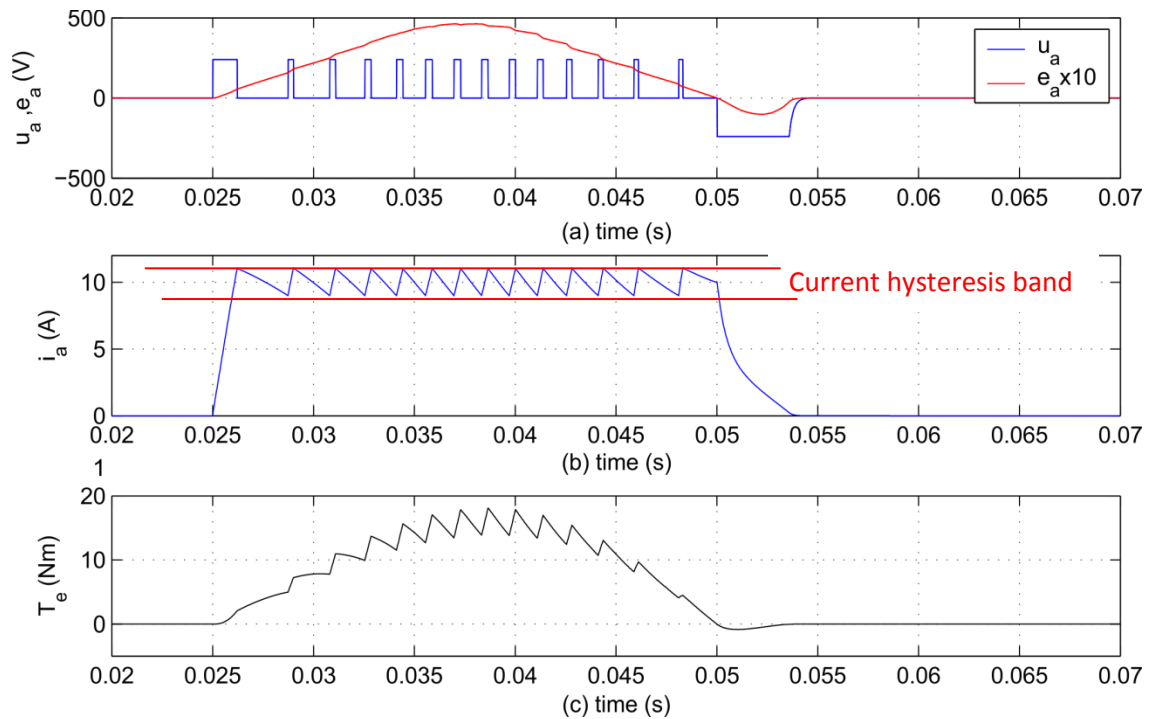

Figure 53: Operating in low speed (6)

Single Pulse Operation

As the rotor speed rises, the induced voltage (back emf) increases. The average phase voltage must be increased to work against the back emf. Beyond a certain speed, the reference current for the torque cannot be reached anymore. The phase is only turned on and off once in one electrical period. The SRM is operated in single pulse mode. The phase voltage and back emf, phase current and torque can be found in Figure 54.

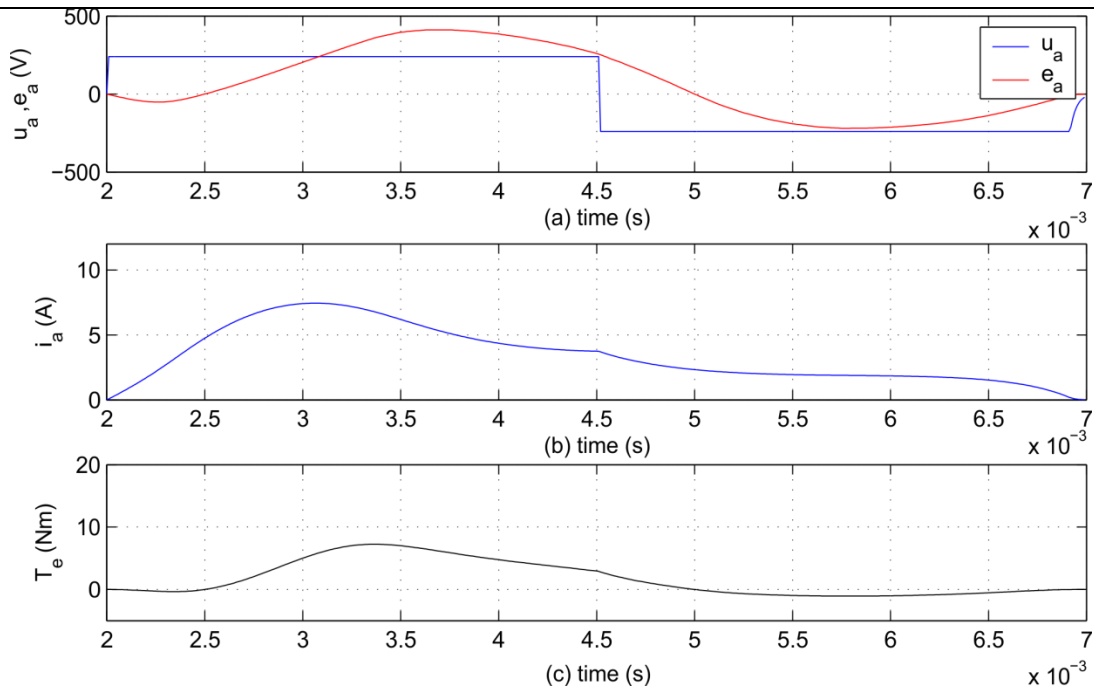

Figure 54: Operating in high speed (6)

Phase Number and Torque Ripple

Since the torque production is only possible between 0° and 180° electrical degrees, it is only possible to produce continuous torque if the SRM has more than 2 phases. In general, a high phase number reduces torque ripple. Figure 55 and Figure 56 show the torque production of a three phase SRM and of a four phase SRM. The solid lines are the torque of one phase, while the dashed lines are the total torque on the rotor shaft.

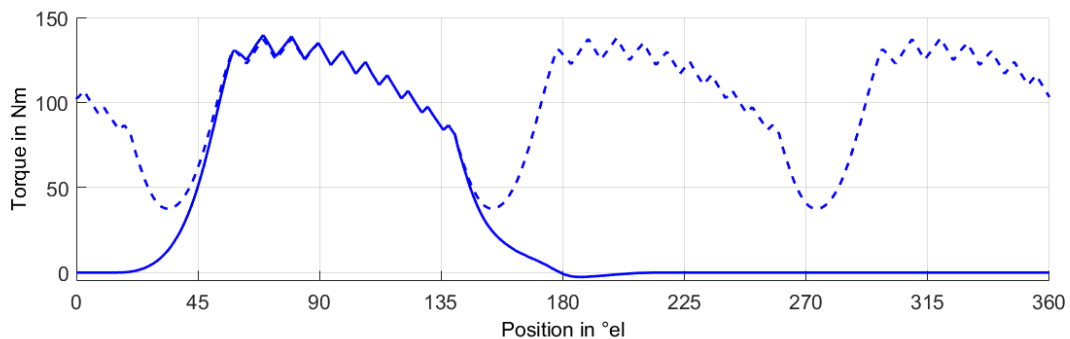

Figure 55: Torque production of a three phase SRM (4)

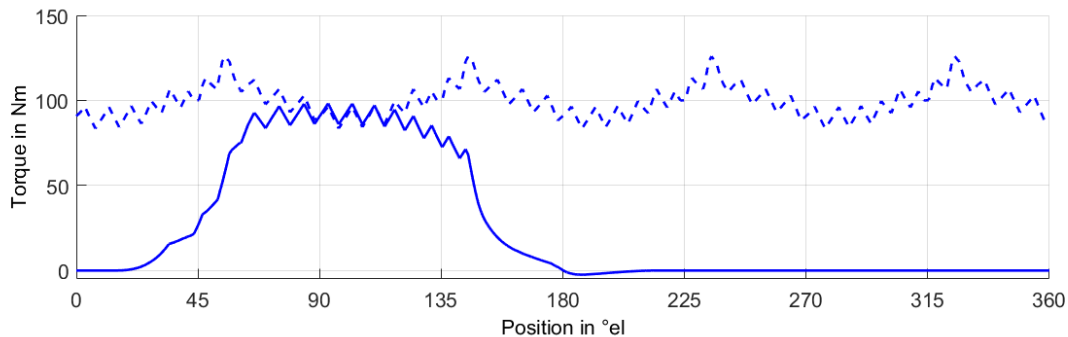

Figure 56: Torque production of a four phase SRM (4)

Notable Features and Ratings

- SRMs can also be used as a stepper motor.
- Its robust structure allows the SRM to run at very high speed (>100,000 rpm).
- High-power SRMs can reach a power rating of several hundred kilowatts.
- SRMs suffer from high acoustics noise, high torque ripple and a lower efficiency than ASM and PMSM. Until today, SRMs can only be found in niche applications.

Strengths / Weaknesses

- Simple construction
- Low cost since no magnets are used
- Robust rotor suitable for high speed operation
- High acoustics noise due to the high radial electromagnetic force
- High torque ripple depending on the number of the phases and the adopted control algorithm
- Low power factor due to the low duty cycle and the high peak current of one phase (0.25 ~ 0.5)

Predominant Applications

- Textile processing industry (operating speeds of 100.000 rpm)
- Centrifuges or compressors, for example a 40kW, high-performance compressors for air conditioning in ICE 3 high-speed trains.
- Household appliances (Foodprocessors e.g. Thermomix from Vorwerk)



Stepper Motor

A stepper motor is an electromechanical device which converts electrical pulses into discrete mechanical movements (27).

Motor Structure and Functional Description

There are three main types of stepper motors:

- Variable Reluctance stepper motor, which has the same structure as a switched reluctance motor (SRM).
- Permanent magnet stepper motor, which has a similar structure as permanent magnet synchronous motor.
- Hybrid synchronous stepper motor.

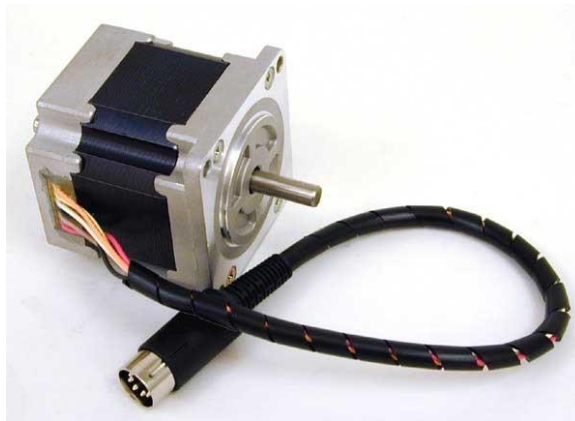

Figure 57: Stepper Motor (28)

Variable Reluctance stepper motor

A variable reluctance (VR) stepper motor is a small-size SRM (for more detail see chapter Motor Characteristics and Motor Control). Compared with the other two types of stepper motors, it is the least complex, cheapest one. The rotation angle at one electrical pulse, which is also called step angle, is the largest among the stepper motors.

It consists of a laminated multi-toothed rotor and a wound stator. When the stator windings are energized with DC current, the poles become magnetized. Rotation occurs when the rotor teeth are attracted to the energized stator poles due to reluctance force (see Forces and Torque Production). Figure 58 shows a four phase variable reluctance stepper motor with 8 stator teeth and 6 rotor teeth. The stepping sequence is demonstrated in Figure 59. Depending on the pulse sequence,



the rotor rotates clockwise or counterclockwise. The motor in Figure 59 has a step angle of 15°.

In general, the step angle θ_{ST} for a variable reluctance stepper motor is given by:

$$\begin{aligned} \theta_S &= 360^\circ/N_S \\ \theta_R &= 360^\circ/N_R \\ \theta_{ST} &= \theta_R - \theta_S \end{aligned}$$

Where θ_S is the stator angle, θ_R is the rotor angle, N_S is the number of stator poles, N_R is the number rotor poles.

Variable reluctance stepper motors have a lower torque density than other two types of stepper motors. They are applied when only a coarse step angle is adequate. The continuous rotational operating of the variable reluctance stepper motor is found in the chapter Motor Characteristics and Motor Control.

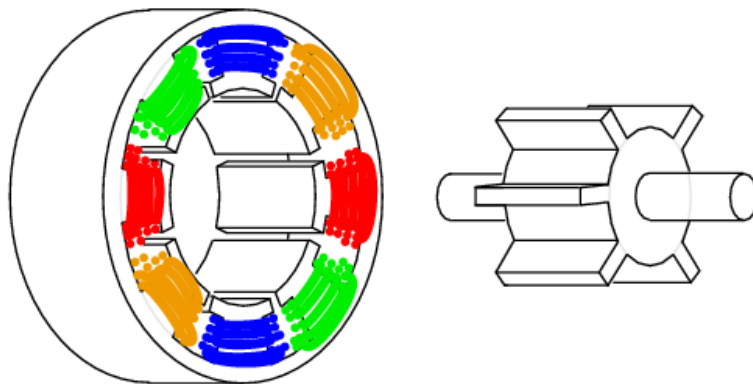

Figure 58: Variable reluctance stepper motor (29)

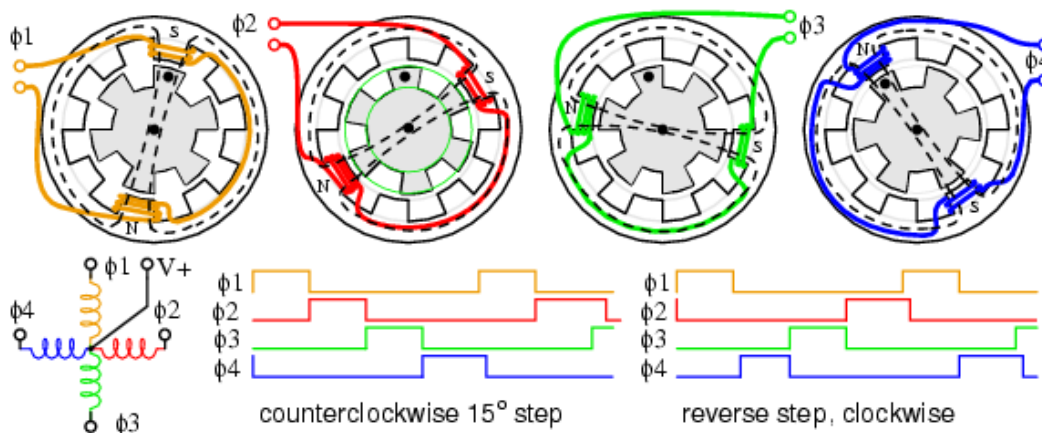

Figure 59: Stepping sequence for variable reluctance stepper (29)



Permanent Magnet stepper motor

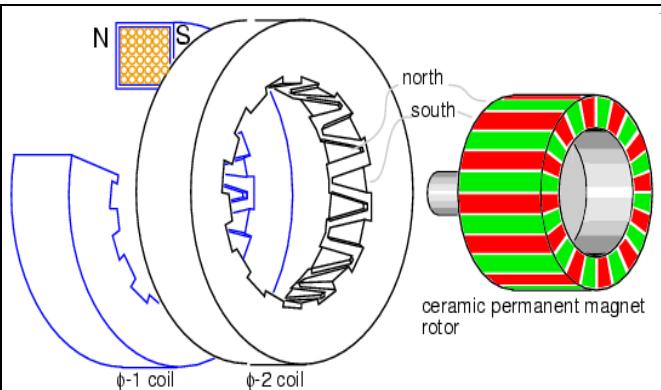

Figure 60: Permanent magnet stepper motor (29)

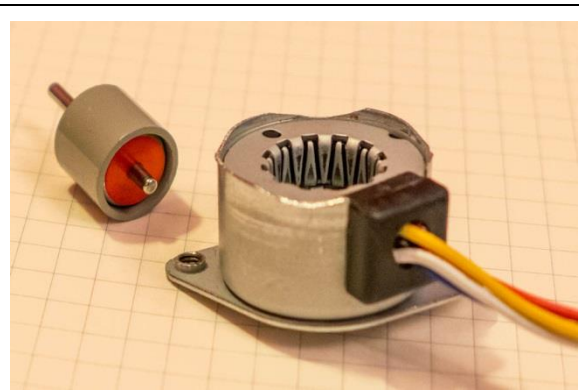

Figure 61: Example of permanent magnet stepper motor (30)

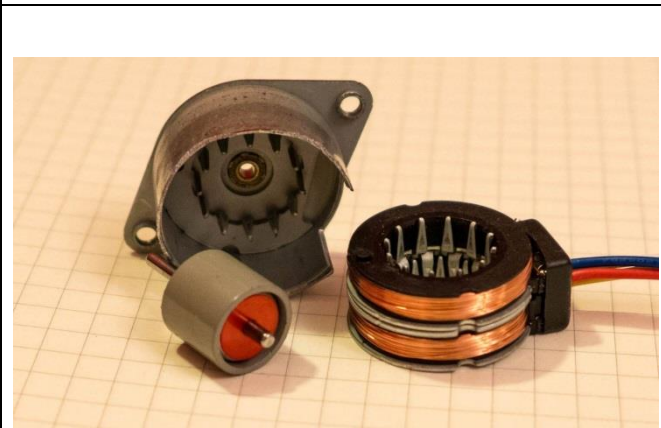

Figure 62: Coils of the example permanent magnet stepper motor (30)

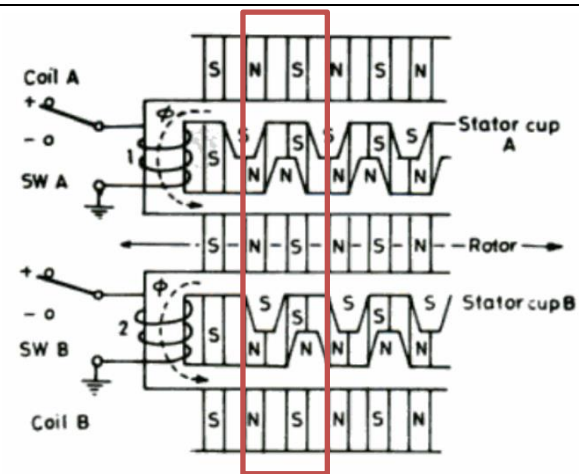

Figure 63: Position hold by current in two phases (31)

The rotor in the permanent magnet (PM) stepper motor has no teeth as with the VR motor. Instead, the rotor is magnetized with alternating north and south poles as shown in Figure 60. The poles in green are the north poles of the magnet, the red poles are the south poles of the magnet. These magnetized rotor poles provide an increased magnetic flux due to the permanent magnets. Because of this, the PM motor exhibits improved torque characteristics when compared with the VR type. Figure 61 and Figure 62 show two pictures of a real PM stepper motor. The north and south poles are not identified by different colors. The step angle is between the VR type and the hybrid stepper motor. It is often used in computer printers to advance paper.

The stator consists of two parts: ϕ -1 coil and ϕ -2 coil. The coils are wound along the circumference of the stator. Each part has the same number of poles as the



rotor. The two parts have a 90 electrical degree offset between them as shown in Figure 63.

In the following only the 4 stator poles and 2 rotor poles as shown inside the red rectangle of Figure 63 are considered, which can be illustrated as shown in Figure 64. It is called wave drive if only one of the two phases is excited at any time. The four holding positions, a, b, c, d, at which the rotor can be held still by the excited current are also shown Figure 65. The electric pulses, which correspond to the four positions, are shown below in the pulse sample. The yellow signal is the current of phase ϕ_1 , the blue signal the respective current of phase ϕ_2 . By feeding this pulse sequence the stepper motor runs clockwise across all holding positions.

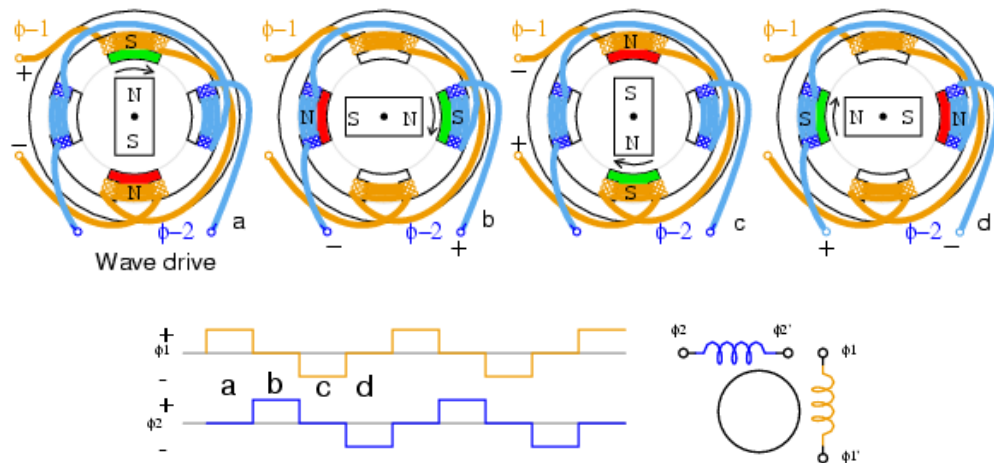

Figure 64: Simplified permanent magnet stepper in wave drive (29)



If both phases are excited at any time, it is called full-step drive as shown in Figure 65. There will be 4 more holding positions with full-step drive. The full-step drive gives the rated torque of the stepper motor, which is higher than the torque generated at wave drive. In wave drive, only one of the two phases is excited. This causes a lower flux linkage in the motor.

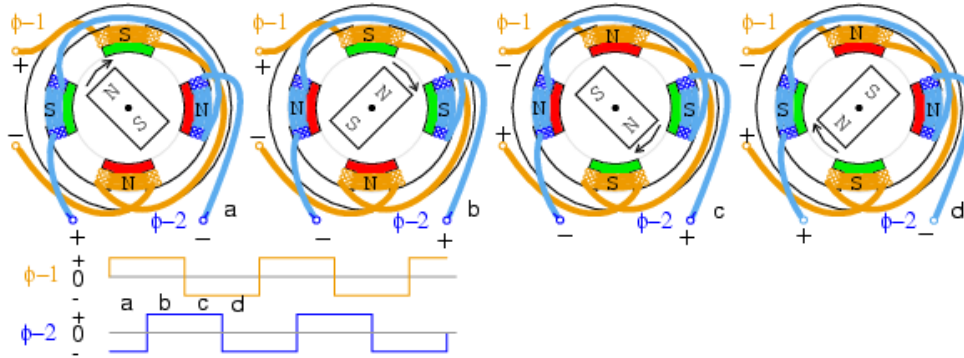

Figure 65: Simplified permanent magnet stepper in full-step drive (29)

Combining the wave drive and the full-step drive leads to in total 8 possible holding positions, which is illustrated in Figure 66. However, this is only possible if the torque demand is lower than the torque provided in wave drive, since the maximum torque are different in these two drive modes.

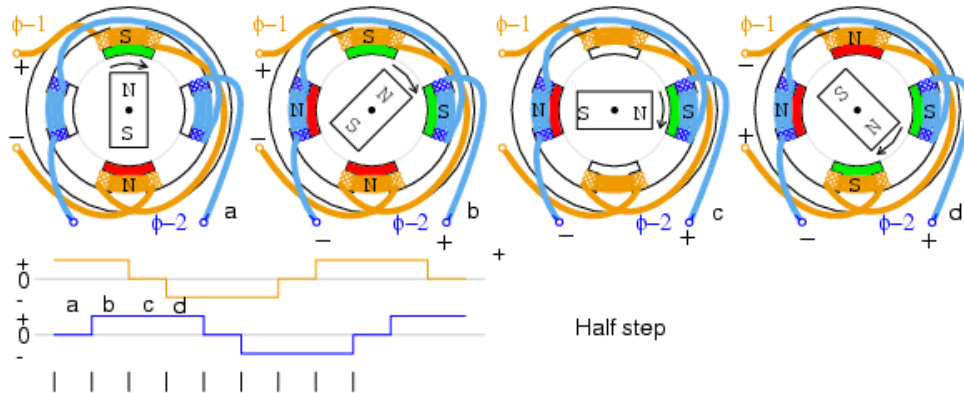

Figure 66: Simplified permanent stepper motor in half step drive (29)

Hybrid Synchronous stepper motor

The hybrid stepper motor combines features of both the variable reluctance stepper and the permanent magnet stepper. Its step angle is smaller than variable reluctance or permanent magnet steppers and it can reach up to a few hundred steps per revolution.

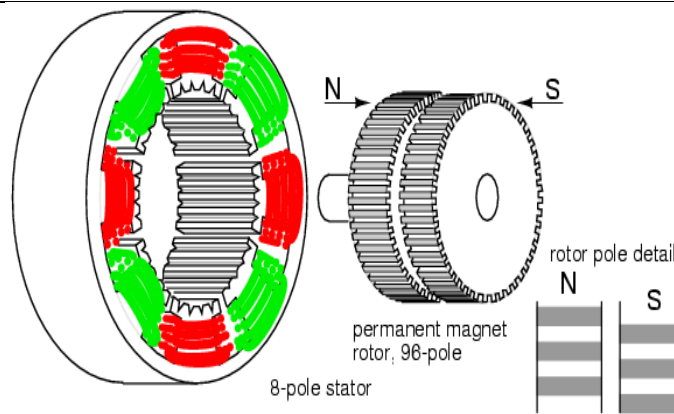

Figure 67: Hybrid synchronous stepper motor (29)

The rotor of the hybrid stepper motor is a cylindrical permanent magnet in form of two disks (Figure 67). They are magnetized along the rotation axis. The two disks are north and south poles respectively. The high amount of rotor poles increases the number of the holding position of the motor. The stator coils (concentrated winding) are wound on the stator poles, similar as in a switched reluctance motor or a brushless DC motor.

Figure 68 shows a simplification of the hybrid stepper motor. Only the teeth in the north-pole disk are visible in the figure on the right. North poles of the stator and the rotor are marked in green. South poles are marked in red. Two electrical poles in phase 1 (ϕ_1, ϕ_1') are shown in the figure on the left. The two electrical poles (ϕ_2, ϕ_2') are neglected in the left figure.

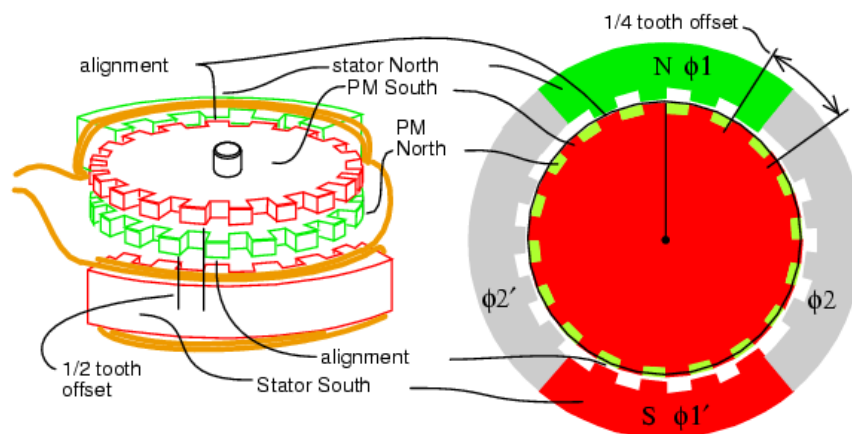

Figure 68: Simplification of hybrid stepper motor (29)



Figure 69 demonstrates the rotation of the rotor in clockwise direction. The pulse sequence is similar as for permanent magnet stepper motor, which is shown below. In hold position (a) in Figure 69, the north pole (green) in one of the two rotor disks is attracted by the stator south pole $\phi 1'$, while the rotor south pole in the other rotor disk is attracted by the stator north pole $\phi 1$. In the next step (b), $\phi 2$ and $\phi 2'$ are switched on. The rotor rotates with a step of half of the rotor tooth width.

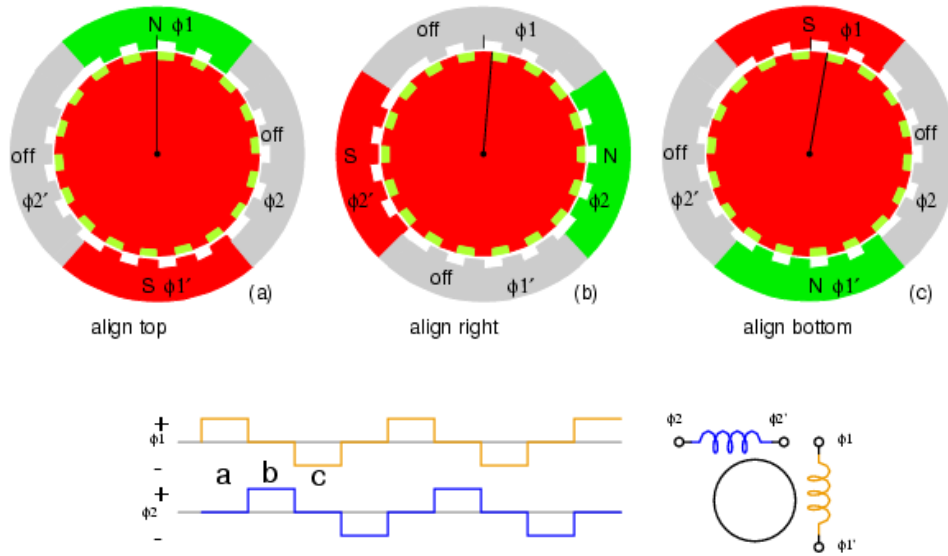

Figure 69: Hybrid stepper motor rotation sequence (29)

Bipolar and Unipolar winding arrangements

There are two basic winding arrangements for the electromagnetic coils: bipolar and unipolar.

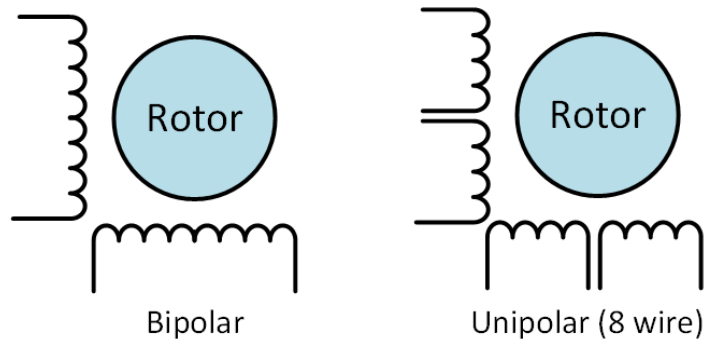

Figure 70: Bipolar and unipolar winding arrangements (32)



“Bipolar motors have a single winding per phase. The current in a winding needs to be reversed in order to reverse a magnetic pole, so the driving circuit must be more complicated, typically with an H-bridge arrangement. ” (33)

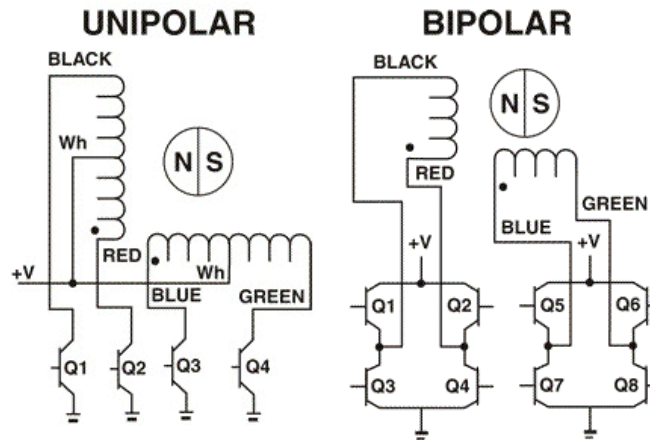

Figure 71: Switches for bipolar and unipolar motor (34)

“A unipolar stepper motor has one winding with center tap per phase. Each section of windings is switched on for each direction of magnetic field. Since in this arrangement a magnetic pole can be reversed without switching the direction of current, the commutation circuit can be made very simple (e.g., a single transistor) for each winding.

Because windings of bipolar motor are better utilized, they are more powerful than a unipolar motor of the same weight. This is due to the physical space occupied by the windings. A unipolar motor has twice the amount of wire in the same space, but only half used at any point in time, hence is 50% efficient (or approximately 70% of the torque output available). Though a bipolar stepper motor is more complicated to drive, the abundance of driver chips means this is much less difficult to achieve.” (33)



Motor Characteristics and Motor Control

Rotation

The sequence of the applied pulses is directly related to the direction of motor shaft rotation. The speed of the motor shaft rotation is directly related to the frequency of the input pulses. The rotation angle is directly related to the number of input pulses applied. (35) The maximum speed of a stepper motor can reach several thousand rpm.

Power

Since stepper motors do not necessarily rotate continuously, there is no power rating. They are small low power devices compared to other motors. (29)

Torque

The torque ratings could reach up to dozens of Nm (36). Most steppers are a few centimeters in diameter with a fraction of 1 Nm torque. (37)

Step angle

The variable reluctance stepper motors usually have the biggest step angle among all three types, which can reach several degrees. The hybrid stepper motors have the highest resolution. The minimum step angle of a hybrid stepper motor can reach several tenths of one degree.

Speed torque characteristics

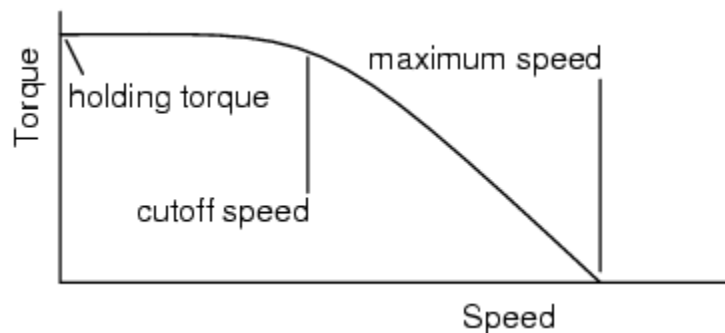

Figure 72: Speed torque characteristics (29)

The torque available is a function of motor speed as illustrated on the speed vs. torque curve. (Figure 72) An energized, holding stepper has a relatively high holding torque rating. There is less torque available for a running motor, decreasing to zero at some high speed. (29) The holding torque is determined by the thermal limitation of the stator winding. Cutoff speed and maximum speed are determined by the electromagnetic design of the motor.



Specification example

The specification of a hybrid synchronous stepper motor looks like this:

COMMON RATEING		SPECIVICATIONS	
STEP ANGLE	1.8°±5%	VOLTAGE	12V
PHASES	2	CURRENT	0.33A
INSULATION RESISTANCE	100Mohm(500V DC)	INDUCTANCE	46±20% Mh
CLASS OF INSULATION	B	RESISTANCE	34±10%
WEIGHT	0.20Kg	HOLDING TORQUE	0.23N.M

Figure 73: Specification of a hybrid synchronous stepper motor (38)

This motor should work with a DC voltage of 12V. The rated current is 0.33A, which is limited by its rated voltage and the winding resistance. No extra current control is needed. Higher driving voltage will cause overcurrent, which could cause thermal damage of the motor. The motor has 2 phases. Each pulse leads to a step angle of 1.8°. The holding torque is 0.23 Nm.

Comparison with servo control system

“Some performance differences between Stepper and Servos are the result of their respective motor design. Stepper motors have many more poles than servo motors. One rotation of a stepper motor requires many more current exchanges through the windings than a servo motor. The stepper motor's design results in torque degradation at higher speeds when compared to a servo. Conversely, a high pole count has a beneficial effect at lower speeds giving the stepper motor a torque advantage over the same size servo motor.

Another difference is the way each motor type is controlled. Traditional steppers operate in the open loop constant current mode. This is a cost savings, since no encoder is necessary for most positioning applications. However, stepper systems operating in a constant current mode create a significant amount of heat in both the motor and drive, which is a consideration for some applications. Servo control solves this by only supplying the motor current required to move or hold the load. It can also provide a peak torque that is several times higher than the maximum continuous motor torque for acceleration.

Steppers are simpler to commission and maintain than servos. They are less expensive, especially in small motor applications. They don't lose steps or require encoders if operated within their design limits. Steppers are stable at rest and hold their position without any fluctuation, especially with dynamic loads.

Servos are excellent in applications requiring speeds greater than 2,000 RPM and for high torque at high speeds or requiring high dynamic response. Steppers are



excellent at speeds less than 2,000 RPM and for low to medium acceleration rates and for high holding torque." (39)

All in all, stepper control systems are less expensive and are optimal for applications that require low-to-medium acceleration, high holding torque, and the flexibility of open or closed loop operation. Servo control systems are best suited to high speed, high torque applications that involve dynamic load changes. (40)

Notable Features and Ratings

- Unlike other motor types such as induction motor or switched reluctance motor, the name "stepper motor" does not indicate the working principle of the motor, but the application of the motor.
- The motors response to digital input pulses provides open-loop control, making the motor simple and cheap to control.
- Stepper motors can be a good choice whenever controlled movement is required. (41) They can be advantageous in applications where control of rotation angle, speed, position is needed.

Strengths / Weaknesses

- The rotation angle of the motor is proportional to the input pulse. (42)
- Precise positioning and repeatability of movement since good stepper motors have an accuracy of 3 – 5% of a step and this error is non-cumulative from one step to the next. (42)
- Very reliable since there are no contact brushes in the motor. (42)
- The motors response to digital input pulses provides open-loop control, making the motor simpler and less costly to control. (42)
- Low efficiency. Motor draws substantial power regardless of load. (43)
- Torque drops rapidly with speed higher than the cutoff speed.

Predominant Applications

Printers, plotters, medical equipment, fax machine, automotive and scientific equipment etc.



Lexicon

Basic Principles of Electric Machines

Forces and Torque Production

An electric machine converts electrical energy into mechanical energy (motor operation) or vice versa (generator operation). The electrical energy is supplied in the form of current and voltage and the mechanical energy is supplied at the shaft in the form of (rotational) speed and torque. The power in an electric machine is proportional to the product of speed and power, $P = \omega \cdot T = 2\pi \cdot n \cdot T$ with the angular speed ω , the rotational speed n and the torque T . Consequently, four quadrants of operation are obtained as a function of the signs of speed and torque (see Figure 74).

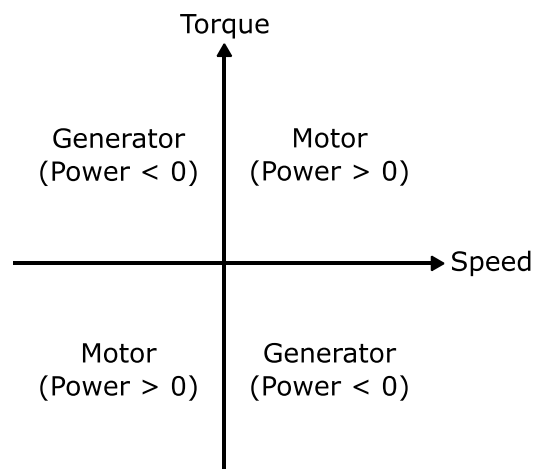

Figure 74: Operation quadrants of electrical drives (4)

The energy conversion uses the magnetic fields in the machine. Magnetic forces are produced in such a direction that the magnetic field lines tend to shorten (the path length of the magnetic field lines between the opposite poles). The torque production due to the magnetic forces acting on the rotor of an electric machine can be related to two different mechanisms:

- Lorentz force: Force on a current-carrying conductor in a magnetic field
- Reluctance force: Caused by the change of the magnetic resistance, the so-called reluctance

Both mechanisms allow the transformation of electrical energy into mechanical energy (motor operation) and vice versa (generator operation).



Force calculation using Lorentz force

The Lorentz force is the force on a current carrying conductor within a magnetic field. Figure 75 shows a conductor of length l which carries the current i . The conductor is located within a magnetic field with the induction B . This induction is orthogonal to the current carrying conductor and the drawing plane. In the figure, this is shown by crosses surrounded by a circle, which represent the virtual backside of an arrow flying into the drawing plane (the direction of the magnetic field corresponds to the direction of the arrow). The resulting force quantity on the conductor is

$$F = B \cdot i \cdot l$$

The direction of the force can be derived according to the right-hand-rule which assigns the directions of cause (current), agency (magnetic field) and effect (force) to an orthogonal system, see Figure 76. As shown in the figure, the direction of force is given as the direction of the middle finger if the thumb points in the direction of the current and the forefinger points in the direction of the magnetic field.

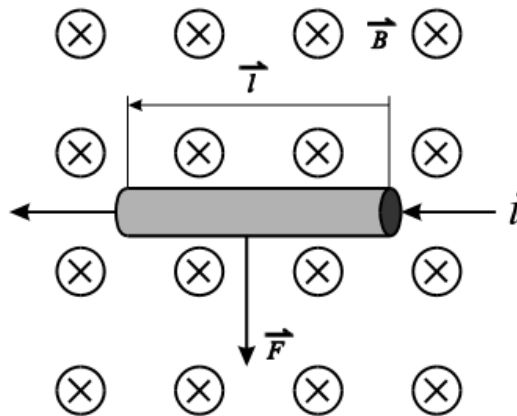

Figure 75: Lorentz force on a current carrying conductor in a magnetic field (4)

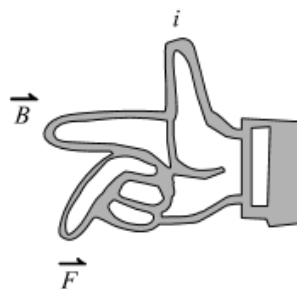

Figure 76: Right-hand rule (4)



If the magnetic field is not orthogonal to the conductor but at an angle α , the force is reduced by the factor $\sin \alpha$: $F = B \cdot i \cdot l \cdot \sin \alpha$

The Lorentz force is the physical fundamental of the torque production inside an electric machine, as it moves a current carrying conductor under the influence of a magnetic field into a predetermined direction.

For the description and control of electric machines, another way of calculating the torque is used. It is based on the same fundamentals but uses the interaction of magnetic flux linkage and the current in the machine for torque calculation. When current and flux linkage are interpreted as space vectors (see chapter Creation of a Rotating Field), the electrodynamic torque T_e is calculated with the vector cross product of both values,

$$\vec{T}_e = \vec{\psi}_m \times \vec{i}$$

In $\alpha\beta$ -coordinates, this results in

$$T_e = \Psi_{m\alpha} \cdot i_\beta - \Psi_{m\beta} \cdot i_\alpha$$

In Figure 77, this relationship is shown for three exemplary current and flux linkage space vector combinations. This figure shows that torque control in an electric machine may be realized by manipulating the current vector relative to the flux vector (6). The grey shaded area in Figure 77 represents the torque magnitude. Maximum torque corresponds to the maximum possible area and is realized when the two vectors, current and flux linkage, are orthogonal (figure in the middle). In contrast, torque becomes zero when the current and flux linkage vector are aligned to each other. In the previous chapter Force calculation using Lorentz force, this would correspond to a current carrying conductor aligned in parallel to the magnetic field (instead of orthogonal alignment).

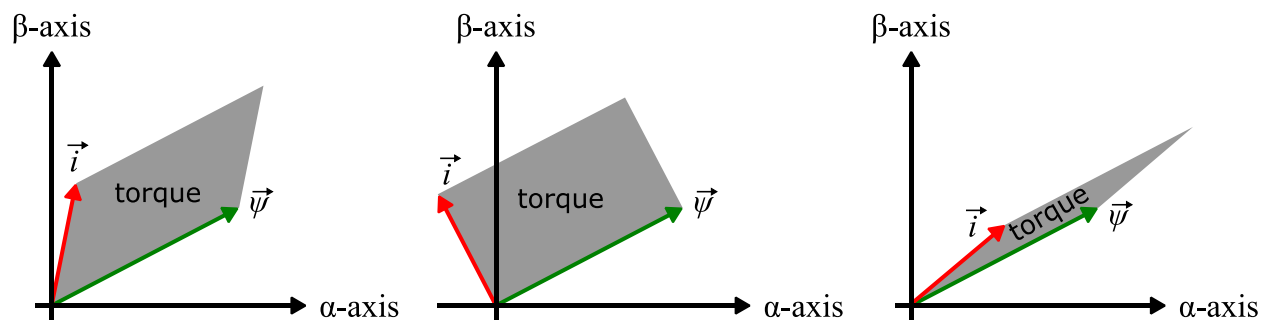

Figure 77: Relationship between current / flux linkage space vectors and torque (6)



Force calculation using reluctance force

The reluctance force is generated through a change of the magnetic resistance and not a force which acts on a current carrying conductor. This force tends to minimize the total reluctance (magnetic resistance) in a magnetic circuit, see Figure 78.

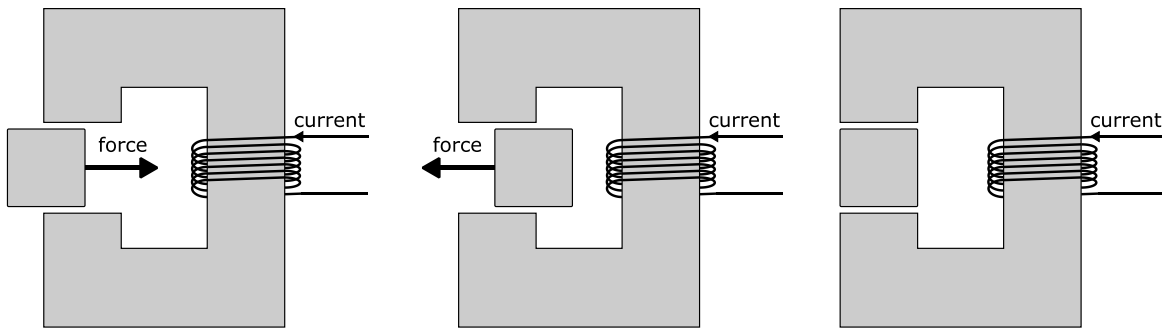

Figure 78: Reluctance force in a magnetic circuit (4)

For an inductance, the general equation for the voltage with respect to ohmic losses is

$$v = R \cdot i + \frac{d\Psi}{dt}$$

Thus, the voltage is proportional to the sum of the product of the resistance and the current and the time dependent change of the flux linkage Ψ . The flux linkage can, in the case of magnetic linear behavior without saturation, be represented as

$$\Psi = L(x) \cdot i$$

with the position dependent inductance $L(x)$. This dependency isn't necessarily a linear position dependency with x . For example in switched reluctance machines, the inductance depends on the angular position θ , yielding $\Psi = L(\theta) \cdot i$.

The mechanical power is the product of force and velocity,

$$P_{\text{mech}} = F \cdot v$$

When evaluating the electrical power as the product of voltage and current, the force F is obtained as a function of the squared current multiplied with the spatial derivative of the inductance,

$$F \sim i^2 \cdot \frac{dL(x)}{dx}$$

Torque production due to the reluctance force is characteristic, e.g. for the switched reluctance machine. More details can be found in the respective chapter.



Creation of a Rotating Field

The synchronous machine and the induction machine are rotating field machines. In contrast to DC machines, the fields in these machines are rotating and not standing still in space. The description of the behavior of spatially rotating fields is usually done using space vectors. They can represent transient spatial waves and should not be confused with phasors, which represent steady state sinusoidal quantities as stationary complex vectors with information about amplitude, angular frequency and initial phase shift.

The direction of a space vector indicates the position of the maximum value of the field whereas the length of the space vector indicates the magnitude or amplitude of the field. The magnitude of the field can be time-dependent and doesn't need to vary sinusoidally over time. However, in rotating field electric machines the magnitude of the field is constant in steady-state operation.

To understand the concept of space vectors, it is instructive to first consider a single-phase system with one winding as indicated in Figure 79. A winding is positioned in the (imaginary) q or quadrature axis (see chapter Coordinate System Transformations for further details). When constant current is impressed in the winding, a flux linkage Ψ_{s1} is produced as is briefly explained in the next chapter Induced Voltages and Back . This flux linkage stands still in space and points into the direction of the d or direct axis. If a sinusoidal current is impressed in the winding, the amplitude of the flux linkage will vary sinusoidally, too. In the space vector representation, this will lead to a varying length of the flux linkage arrow at each time instant. The complex notation of the coordinate system with $\underline{x} = x_d + j \cdot x_q$ is used due to its simplicity compared to a notation using trigonometric functions.

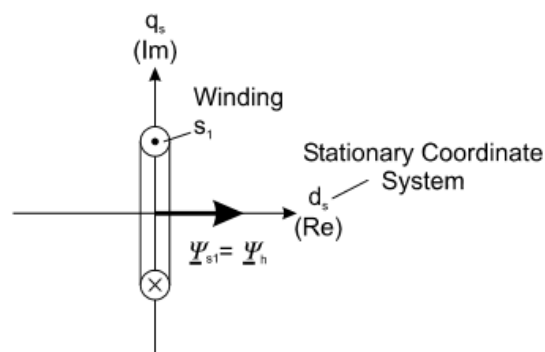

Figure 79: Producing flux linkage with one winding (4)

In a next step, a three-phase system with three windings S_1 , S_2 and S_3 as shown in Figure 80 is considered. The three windings are spatially shifted by 120° with the current directions defined in Figure 80. Each of the windings produces a flux



linkage Ψ_{s1} , Ψ_{s2} and Ψ_{s3} which is orthogonal to the respective winding. These flux linkage vectors are non-rotating vectors because each winding is stationary (same as with the one-phase system above).

The superimposition of the three flux linkages forms the total flux linkage of the system, Ψ_h . When all three currents in the windings are symmetric, i.e. they are all sinusoidal waveforms with the same amplitude and they are phase shifted by 120° , the total flux linkage becomes a space vector with constant length that rotates spatially with the same frequency ω as the currents.

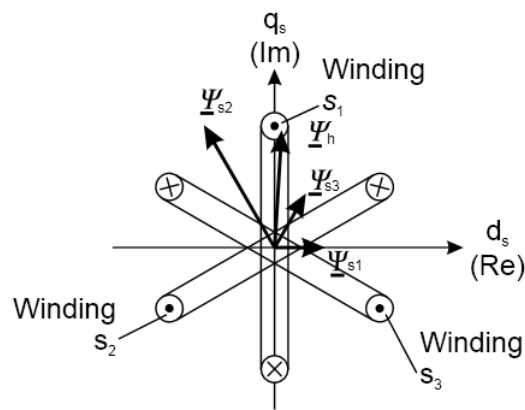

Figure 80: Flux linkage of a three-phase system (4)

To sum it up, a three-phase winding set, which is fed by three-phase symmetric (e.g. sinusoidal) current sources, produces a rotating field.

Induced Voltages and Back Emf

In the previous chapter, Force calculation using Lorentz force, the force on a current carrying inductor in a magnetic field is explained. The same principles are valid, when a conductor is moved in a magnetic field B with velocity v as shown in Figure 81. A voltage is then induced in the conductor that is proportional to the magnetic field B and the speed of the coil v . In the case of a conductor loop, a current would be induced in the loop.

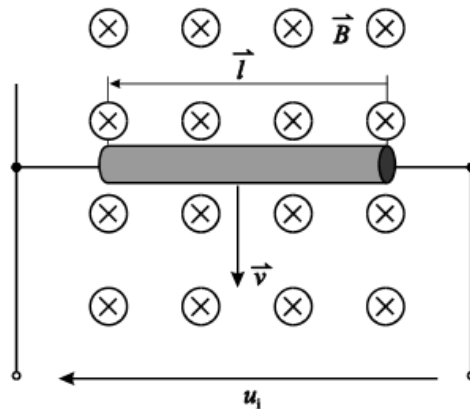

Figure 81: Generation of an induced voltage (4)

If a voltage source is connected to the clamps in Figure 81 the circuit is closed and a current can flow. If resistive losses are taken into account, the voltage v is

$$v = R \cdot i + \frac{d\Psi}{dt} = R \cdot i + L \cdot \frac{di}{dt} + v_i$$

The voltage drop due to the change of the flux linkage over time, $\frac{d\Psi}{dt}$, is related to the self-inductance of the inductance L and to the induced voltage caused by the movement v_i .

In rotating electric machines the rotor commonly has its own magnetic field, either due to magnets or due to a winding in the rotor. As the stationary stator winding is exposed to this rotating field, an additional voltage is induced in the stator winding that is in opposing direction to the voltage applied to the stator winding. This is due to the fact that this induced voltage counteracts to the applied voltage. It is therefore called back-electromotive force or back emf.

The back emf is proportional to the speed of the machine. With rising speed the effective voltage applied to the winding becomes less and, thus, less current is flowing in the motor. At one speed, the back emf becomes equal to the applied voltage and the speed cannot be raised any further. At this so called corner point (base speed point), the flux in the machine has to be weakened to decrease the back emf to allow for higher speeds. See the topic field weakening for the different machine types for further information on how this is done from control perspective for the different machine types.



Position Sensors in Electric Machines

Many control methods for electric machines depend on a sufficiently accurate information about the rotor position and/or rotor speed (the rotation direction is indicated by the sign of speed). This chapter introduces some commonly used sensors for position and speed determination.

A well-known method to measure speed in an analog way is to use a tachometer. A DC generator (see the respective chapter for details) with linear characteristic and low load can be used for this purpose. As the voltage of the generator is proportional to the speed, it can be used in either analog circuits or digital systems to represent the magnitude of speed. In a digital system, the speed can be calculated from the voltage measurement implying that the generator parameters are known and constant in the respective operating range.

Alternatively, digital speed measurement using optical or magnetic methods is possible. The optical method is usually based on the reflecting or transmitting of light. In Figure 82, the transmitting light method is shown. A light beam is sent through a slotted disc, which is composed of permeable and impermeable cells. This method allows speed measurement, but neither the absolute position nor the rotational direction is measurable.

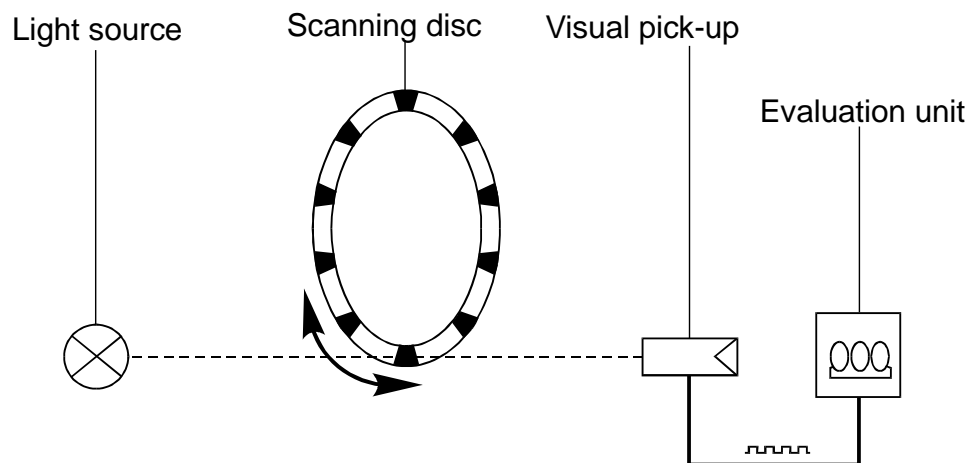

Figure 82: Optical incremental position encoder (4)

An example of magnetic encoders is illustrated in Figure 83. This method uses the change of magnetic reluctance of a moving toothed wheel. Due to the change of flux in the magnetic circuit, an ac-voltage proportional to the speed is induced. The voltages of the two coils, u_A and u_B , are measured. An idealized waveform is shown in Figure 84. With this type of sensor, the rotational direction is measurable, but the absolute position cannot be obtained.

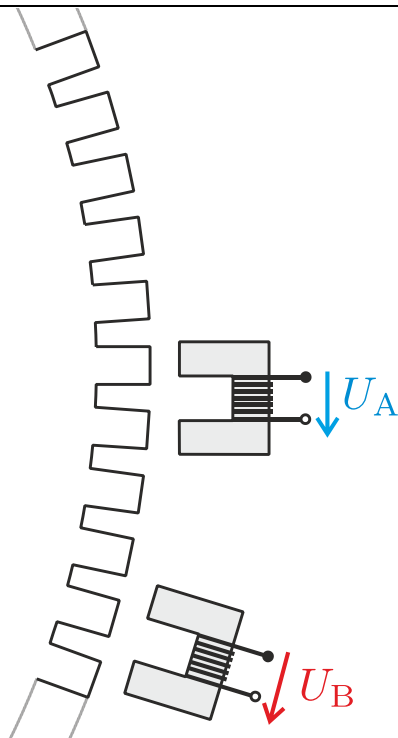

Figure 83: Magnetic incremental position encoder (schematic) (4)

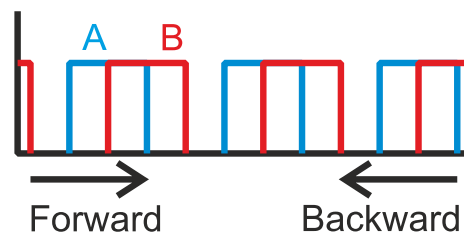

Figure 84: Magnetic incremental position encoder (electrical pulses) (4)

For the measurement of the absolute position, the so called absolute encoders are necessary. They can be built in a similar way as the optical incremental position encoder in Figure 82. Instead of a simply slotted disc, the disc has to generate an optical bit code (e.g. gray code). The required precision can be set by the length of the bit code. The sensor reads the bit code and determines the rotor position due to the knowledge of the positions of the code words. Speed measurement is possible, too, as the code varies with rotor position and the change rate is directly proportional to the rotor speed.

Another type of absolute position encoders is the resolver as shown in Figure 85. The resolver consists of three coils (additional small coils in a machine). Two of them are mounted stationary with 90° shift and one is mounted on the rotating shaft (orthogonal to the shaft). The rotor coil is supplied with a high-frequency AC voltage. The flux linkage produced by this coil depends on the rotor position and it induces voltages in the two stator coils that are, as a consequence, position dependent, too. The measured voltages of the stator coils can then be used to calculate the absolute position of the rotor.

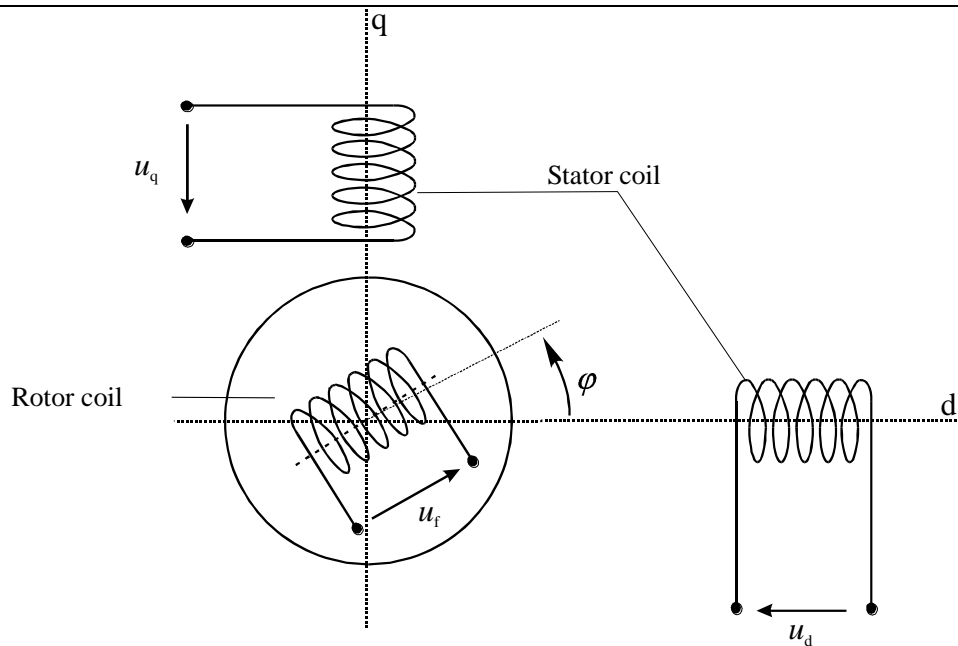

Figure 85: Resolver for absolute position measurement (4)

The state-of-the-art type of absolute position resolvers is the variable reluctance (VR) type resolvers. Their principle structure is shown in Figure 86. The working principle of this resolver type is the sinusoidal change of reluctance with respect to the rotor position. This is shown in Figure 87 in terms of the inductance change over rotor position ($L(\theta)$). High frequency currents are injected in the stator windings and the effective inductance value is calculated due to its inverse proportionality with the current slope ($\frac{di}{dt} = \frac{u}{L(\theta)}$). The rotor position is then calculated with the known inductance values (with L_0 and $L(\theta_{el})$ being resolver specific parameters) and using the arc sine as

$$\theta_{el} = \arcsin\left(\frac{L(\theta_{el}) - L_0}{\hat{L} - L_0}\right)$$

The main advantage of the VR-type resolver is the absence of a field-winding mounted on the rotor as is needed for the resolver type.

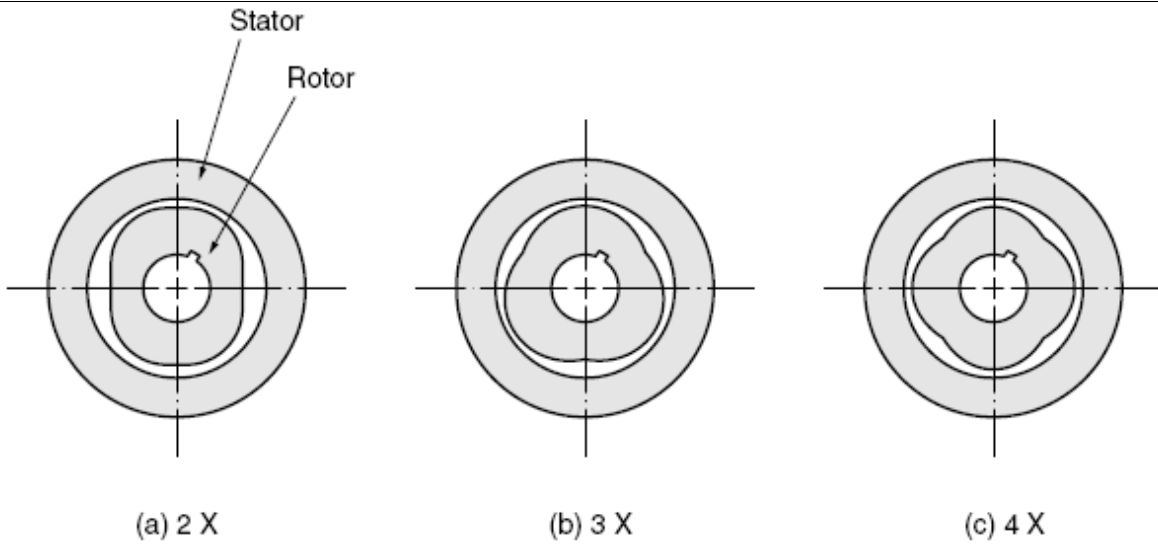

Figure 86: Examples of rotor shapes of the VR-type resolvers (4)

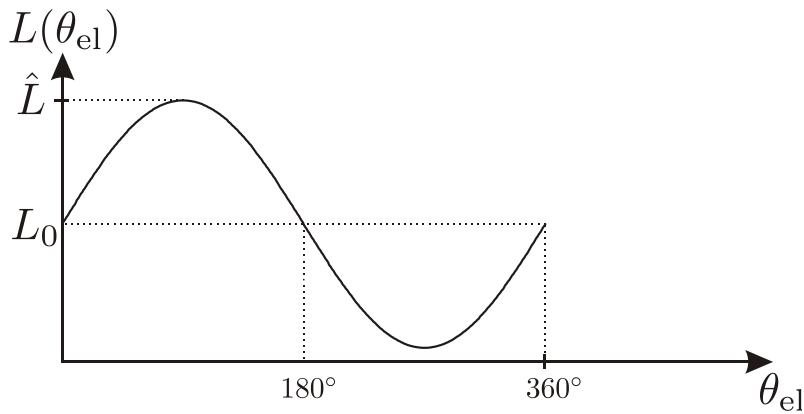

Figure 87: VR-Resolver: Change of inductance as function of the rotor position (4)

Different methods exist that allow eliminating the position sensor and instead using the electric machine itself to determine rotor position and speed. These methods are often referred to as (position) sensorless control schemes and can be found in literature, e.g. (44).



Vector Control

In the early 1970s, a new control method for variable-frequency drives using rotating field electric machines was invented, the Field Oriented Control (FOC) (8), (7), which is a type of vector control. The main characteristic of vector controls is the identification of the three-phase stator current system as an orthogonal two-phase system (see the following chapter Coordinate System Transformations). Each of the two parameters, which form the current space vector, directly controls one of the main machine magnitudes, flux linkage and torque. This fact is a clear difference to scalar control based on the three-phase system as, for example, voltage-to-frequency (also found as voltage-to-hertz) control for induction machines.

From a historical point of view, vector control methods have become popular with increasing availability and usage of microprocessors starting in the 1980s. Today's microcontrollers and DSPs have sufficient computational power at a comparably low price enabling widespread use of them in power electronics and electric machines control.

Coordinate System Transformations

The analysis of three-phase systems can become quite complex. A commonly used way to simplify this analysis is a mathematical transformation of the three-phase system to a two-phase system (45). Even systems with more than three phases can be simplified using adapted transformations. These transformations are the basic principle of vector control in electric machines and they are used for the space vector representation of the three-phase system.

The most important transformations, the alpha-beta- ($\alpha\beta$ -) and the d-q-transformation for symmetric three-phase systems, are presented in the following.

Alpha-Beta-Transformation or Clarke-Transformation

The $\alpha\beta$ - or Clarke-transformation describes a transformation of the three-phase system to a two-phase system with a rectangular coordinate system which is fixed to the stator and, hence, a stationary coordinate system. Its abscissa is the real alpha (α) axis and is aligned with the first inductance of the machine (U in UVW-described machine phases). The ordinate is the imaginary beta (β) axis. Hence, the $\alpha\beta$ -coordinate system is a Cartesian coordinate system for complex numbers with both, α and β part being real numbers.

The arrangement of the axes and its relation to the machine inductances is shown in Figure 88.

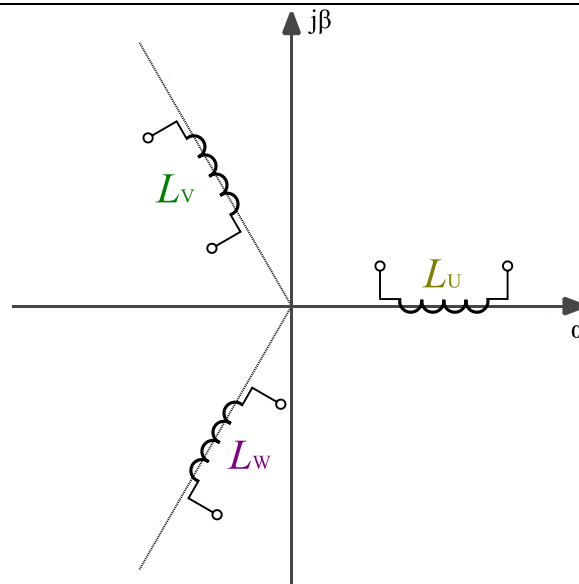

Figure 88: Arrangement of the $\alpha\beta$ -coordinate system (46)

The mathematical representation of this transformation, here for the phase currents, is as follows:

$$\begin{bmatrix} I_{\alpha} \\ I_{\beta} \end{bmatrix} = C \cdot \begin{bmatrix} 1 & -\frac{1}{2} & -\frac{1}{2} \\ 0 & \frac{\sqrt{3}}{2} & -\frac{\sqrt{3}}{2} \end{bmatrix} \cdot \begin{bmatrix} I_U \\ I_V \\ I_W \end{bmatrix}$$

The inverse transformation is

$$\begin{bmatrix} I_U \\ I_V \\ I_W \end{bmatrix} = \frac{1}{C} \cdot \begin{bmatrix} \frac{2}{3} & 0 \\ -\frac{1}{3} & \frac{1}{\sqrt{3}} \\ -\frac{1}{3} & -\frac{1}{\sqrt{3}} \end{bmatrix} \cdot \begin{bmatrix} I_{\alpha} \\ I_{\beta} \end{bmatrix}$$

The factor C can theoretically be chosen free. Two particular values are of special importance. Choosing $C = \frac{2}{3}$ allows for an amplitude invariant transformation. The amplitude of the complex space vector is then the same as the amplitude of the three-phase current, $\hat{I}_{\alpha\beta} = \hat{I}_{UVW}$. On the other hand, choosing $C = \sqrt{\frac{2}{3}}$ allows for a power invariant transformation which conserves the power with $p_{\alpha\beta} = p_{UVW}$.

Consequently, it is $\hat{I}_{\alpha\beta} = \sqrt{\frac{3}{2}} \cdot \hat{I}_{UVW}$ for the power invariant value of C and $p_{\alpha\beta} = \frac{2}{3} \cdot p_{UVW}$ for the amplitude invariant value of C .



To sum it up:

$$C = \frac{2}{3} \quad \text{amplitude invariant transformation}$$

$$C = \sqrt{\frac{2}{3}} \quad \text{power invariant transformation}$$

Both values are valid to use and they are both frequently used in literature.

D-Q-Transformation or Park-Transformation

The dq- or Park-transformation is similar to and extends the $\alpha\beta$ -transformation as it transforms the three-phase system to a two-phase coordinate system, too. The main difference is the coordinate system as it is not stationary and fixed to the first inductance but rotates with electrical frequency of the rotor ω_{rotor} . This results in a transformation of the rotating field in two constant values, the d (direct) and q (quadrature) part of the complex number $\underline{x} = x_d + j \cdot x_q$.

The mathematical expression of this transformation for symmetrical three-phase systems is

$$\begin{bmatrix} I_d \\ I_q \end{bmatrix} = \begin{bmatrix} \cos \theta & \sin \theta \\ -\sin \theta & \cos \theta \end{bmatrix} \cdot \begin{bmatrix} I_\alpha \\ I_\beta \end{bmatrix} = C \cdot \begin{bmatrix} \cos \theta & \cos \theta - \frac{2\pi}{3} & \cos \theta - \frac{4\pi}{3} \\ -\sin \theta & -\sin \theta - \frac{2\pi}{3} & -\sin \theta - \frac{4\pi}{3} \end{bmatrix} \cdot \begin{bmatrix} I_U \\ I_V \\ I_W \end{bmatrix}$$

The inverse transformation is

$$\begin{bmatrix} I_\alpha \\ I_\beta \end{bmatrix} = \begin{bmatrix} \cos \theta & -\sin \theta \\ \sin \theta & \cos \theta \end{bmatrix} \cdot \begin{bmatrix} I_d \\ I_q \end{bmatrix}$$

or

$$\begin{bmatrix} I_U \\ I_V \\ I_W \end{bmatrix} = \begin{bmatrix} \cos \theta & -\sin \theta \\ \cos \theta - \frac{2\pi}{3} & -\sin \theta - \frac{2\pi}{3} \\ \cos \theta - \frac{4\pi}{3} & -\sin \theta - \frac{4\pi}{3} \end{bmatrix} \cdot \begin{bmatrix} I_d \\ I_q \end{bmatrix} \quad \text{for amplitude invariant transformation}$$

$$\begin{bmatrix} I_U \\ I_V \\ I_W \end{bmatrix} = \sqrt{\frac{2}{3}} \cdot \begin{bmatrix} \cos \theta & -\sin \theta \\ \cos \theta - \frac{2\pi}{3} & -\sin \theta - \frac{2\pi}{3} \\ \cos \theta - \frac{4\pi}{3} & -\sin \theta - \frac{4\pi}{3} \end{bmatrix} \cdot \begin{bmatrix} I_d \\ I_q \end{bmatrix} \quad \text{for power invariant transformation}$$

The whole transformation process is shown in Figure 89 from the symmetric three-phase system i_a, i_b, i_c to the stationary two-phase $\alpha\beta$ -system and further to the rotating two-phase dq-system. The upper parts of the figure show a space vector representation of the currents and the lower parts show the time dependent characteristics of the three-phase abc-system on the left, the $\alpha\beta$ -system in the middle and the dq-system on the right.



It is clearly visible that the $\alpha\beta$ -system still shows sinusoidal waveforms for the α - and the β -component. There are two space vectors shown for the time instants t_1 and t_2 as marked on the lower plot. In the rotating dq-frame, the values become constant. This is very helpful for the control of three-phase machines (or multi-phase machines in general), as all control methods and principles available for constant quantities, e.g. PI controllers, become applicable.

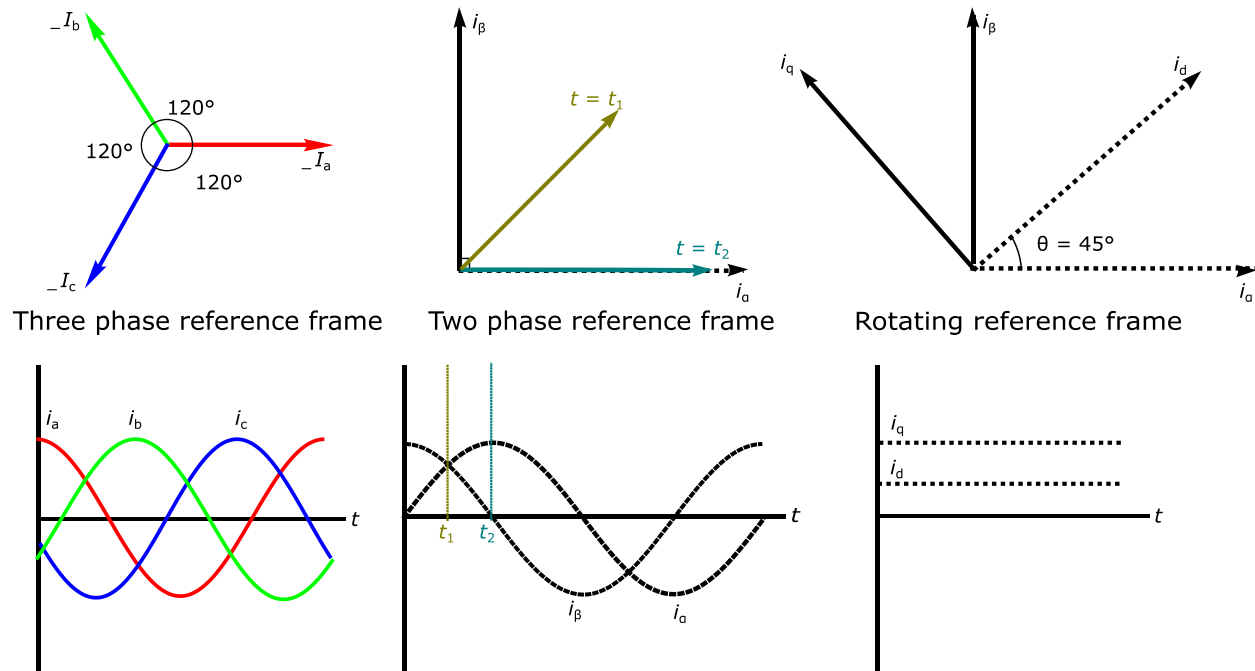

Figure 89: Transformations of a three-phase system (4)



Field-Oriented Control (FOC)

In Field-Oriented Control (FOC), a three-phase induction or synchronous machine is controlled in a way that is similar to the control of DC machines. FOC is based on an inverted model of the machine to be controlled. Hence, its precision depends on accurate machine parameters and the effects taken account of in the model. FOC allows independent control of torque and flux linkage under transient conditions (6).

Field-oriented control can be divided in two different types, direct field-oriented control (DFOC) and indirect field-oriented control (IFOC). Schematics of both principles are shown in Figure 91 (IFOC) and Figure 92 (DFOC). IFOC uses the position sensor and the reference values of torque and flux linkage to calculate the reference angle for the dq-transformation whereas DFOC estimates this reference angle and the flux linkage vector using the measured electrical quantities voltage and current. A general structure of field-oriented control drive is shown in Figure 90.

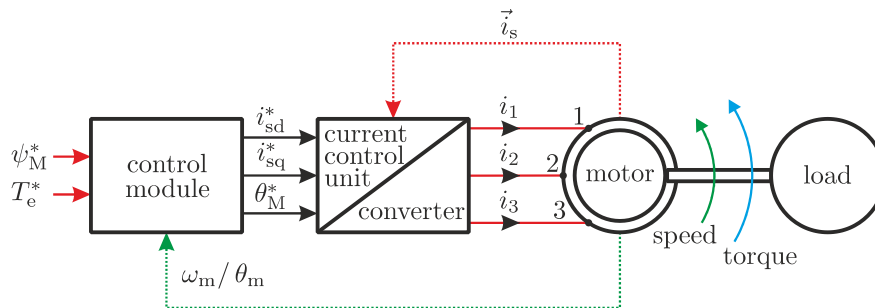

Figure 90: Field-oriented control drive structure (6)

Based on the reference values of flux linkage ψ_M^* (the * indicates reference values) and torque T_e^* and the measured mechanical speed ω_m and/or mechanical angle θ_m , the reference currents i_{sd}^* (flux-producing current) and i_{sq}^* (torque-producing current). A current control unit then uses the measured phase currents to set the reference currents using for example PI controllers with a PWM voltage source inverter (VSI).

To sum up, FOC controls torque and flux linkage indirectly by field-oriented current vector components.

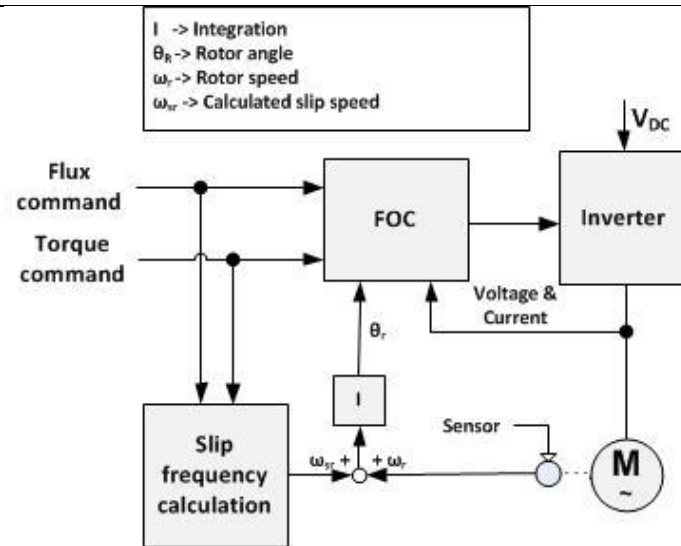

Figure 91: Block diagram of indirect field-oriented control (IFOC) (47)

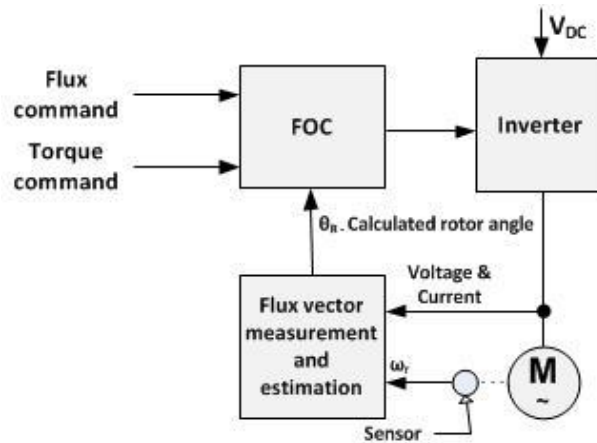

Figure 92: Block diagram of direct field-oriented control (DFOC) (48)

Further information to field-oriented control can be found in the induction machine handbook. There, the single steps of field-oriented control are explained in more detail.



Direct Torque Control (DTC)

Direct Torque Control (DTC) is another type of vector control principle. Figure 93 shows a block diagram of DTC. The phase currents and phase voltages are measured to estimate flux linkage and torque of the electric machine. The estimated values are then compared to the reference values in hysteresis (or so called “bang-bang”) controllers. That means, that the switching signals are changed only when the deviation between estimated and reference value is larger than defined maximum values.

Thus, in DTC torque and flux are controlled directly and there are no PI current controllers as in field-oriented control. DTC provides a variable switching frequency as no modulator is needed due to the direct setting of the switching signals by the hysteresis controllers and a downstream look-up table. However, there are DTC methods which operate at constant switching frequency, too (49).

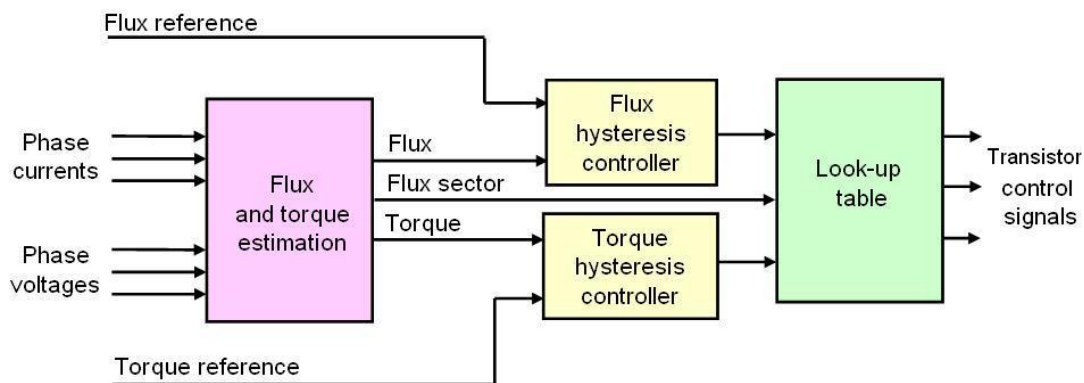

Figure 93: Block diagram of direct torque control (DTC) (50)

Losses in Electric Machines

In electric machines different loss types exist. A breakdown of the different loss types is shown in Figure 94 exemplary for an induction machine. The losses are separated in stator and rotor losses and further on in copper losses P_{Cu} , iron losses P_{Fe} and additional losses P_{suppl} . The different loss types and their origin are explained in the following.

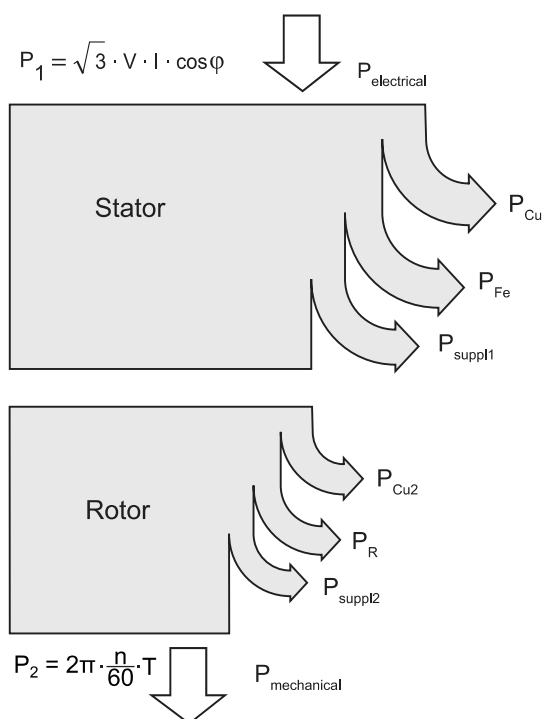

Figure 94: Breakdown of losses in an electric machine (exemplary for an induction machine) (51)

First of all, there are copper losses P_{Cu} due to the ohmic resistance R_{Cu} of the winding's wires, which are usually made from copper, or any other kind of current conducting materials. The copper losses are proportional to the squared current as per Ohm's law,

$$P_{Cu} = I^2 \cdot R_{Cu}$$

Copper losses are in general independent of the frequency, they appear in DC as well as in AC machines. The ohmic resistance depends on the winding conductor material and its parameters. At high frequencies, skin effect can appear in the windings. This is usually negligible for stator windings, but the effect can appear in the rotor windings, e.g. of induction machines. The skin effect describes the tendency of alternating current to become distributed within a conductor such that



the density is largest near the surface of the conductor (52). This results in an increased ac resistance of the conductor yielding increased losses.

Another loss type is the iron loss P_{fe} . Iron losses consist of two separate components, eddy-current losses P_{eddy} and hysteresis losses P_{hys} :

$$P_{fe} = P_{eddy} + P_{hys}$$

Both fractions are explained in the following. Eddy current losses arise due to an induced voltage in the iron yoke of a machine when alternating current is supplied to the windings. These induced voltages lead to compensating eddy currents in the conducting iron (53). This results in eddy current losses which are also called current heat losses. To reduce these losses, stator and rotor are built as laminations with thin iron sheets that are isolated to each other. The thinner the sheets, the lower are the eddy current losses.

The iron material, from which stator and rotor of electric machines are made, consists of many small "elementary magnets" that align due to the magnetic field created by the windings. This results in an amplification of the magnetic field strength H to the resulting magnetic flux density B . To enable a specific flux density in the air gap of an electric machine, a much lower magnetization effort by impressing current into the windings is needed for iron compared to pure air. Consequently, the iron acts as a flux conductor.

One characteristic of magnetic materials is the hysteresis curve. A positive magnetic field, created by a current in the winding, produces a positive magnetic flux density in the material. When the current is switched off, the magnetic field strength becomes zero, but a specific polarization remains in the magnetic material, the remanence flux density B_R . Only by applying a negative field, the flux density can become zero. This happens at the coercitive field strength $-H_{CB}$. When the magnetic field is further decreased, the magnetic flux becomes negative, too. This results in the characteristic hysteresis loop shown in Figure 95.

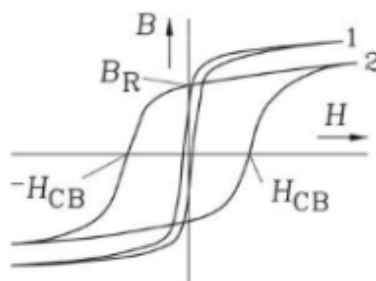

Figure 95: B(H)-characteristic of magnetic materials (53)

1 = soft-magnetic material, e.g. iron / 2 = hard-magnetic material, e.g. permanent magnets



For alternating current electric machines, the currents change their sign sinusoidally, thus the sign of the magnetic field changes, too. The hysteresis loop is then run through counter-clockwise. The area inside this loop correlates to the hysteresis losses P_{hys} . They can be explained with friction when the elementary magnets in the iron re-align due to the change of the external field. The hysteresis losses are proportional to the frequency of the alternating current, $P_{\text{hys}} \sim f$. As all other loss types, they cause thermal stress in an electric machine.

The iron losses can be described using the Steinmetz equation which describes these losses as a function of frequency and flux linkage

$$P_{fe} = k \cdot f^\alpha \cdot \psi^\beta$$

The parameters α and β are material parameters. For example for ferrites, α is a value between 1.1 and 1.9 and β is between 1.6 and 3 (54).

Further on, additional losses can arise for example due to harmonics in the current or due to the skin effect in the wires. On the mechanical side, losses occur in the bearings. In an electrical drive consisting of the electric machine and a gearbox, the losses in this gearbox have also to be taken into account.

The relative contribution of the different loss types greatly depends on the different machine types and on the specific design of a machine, too.



Efficiencies of Electric Machines

Efficiency Classes

The IEC, the International Electrotechnical Commission, published the IEC/EN 60034-30 standard on efficiency classes for low voltage AC motors in late 2008 (55). This standard defines new efficiency classes IE1, IE2, IE3 and IE4 that replace the older classification EFF3 (low efficiency), EFF2 (standard efficiency) and EFF1 (high efficiency) issued by the European Committee of Manufacturers of Electrical Machines and Power systems (CEMEP) in 1998 as a voluntary agreement of motor manufacturers.

The new efficiency classes are valid for induction motors (IE4 defined in IEC 60034-31:2010 for synchronous motors, too) and are as follows:

- IE1: standard efficiency
- IE2: high efficiency
- IE3: premium efficiency
- IE4: super premium efficiency

The standard covers single-speed, three-phase machines operated at grid frequencies of 50 Hz or 60 Hz (direct online operation) with 2, 4 or 6 poles. The power range is specified for output powers from 0.75 kW to 350 kW and the rated voltage is specified for up to 1000 V. Motors for solely converter operation are not covered, nor motors that are completely integrated into a machine and, thus, cannot be tested separately. Figure 96 shows the efficiency classes for 4 pole motors being operated at 50 Hz. For different pole number or 60 Hz operation, different efficiency values are valid.

Since 01.01.2015, new motors sold in the European Union have to be specified at least as IE3 (IE2 for inverter-driven machines) for 7.5 kW to 375 kW power rating according to the EU Commission Regulation 640/2009 (56). From on 01.01.2017, this becomes valid for all motors from 0.75 kW to 350 kW.

With the standard IEC 60034-30-1, published in March 2014, the IE4 level was included as well as 8-pole motors and an extended power range from 0.12 kW to 1000 kW. Figure 97 shows a table of different machine types according to IEC 60034-30-1 and their potential for energy-efficiency.

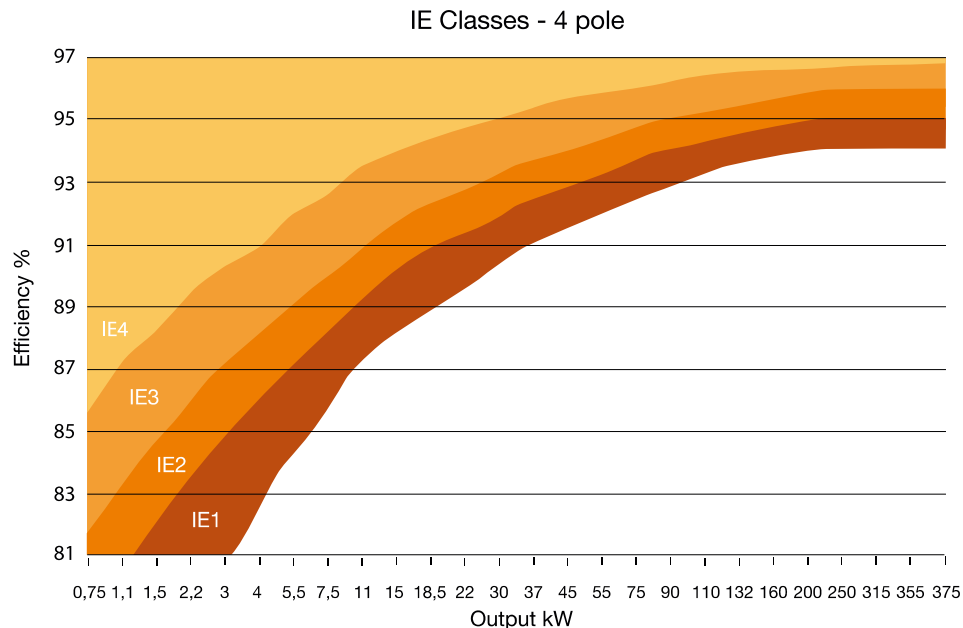

Figure 96: IE efficiency classes for 4-pole (2 pole pairs) motors at 50 Hz (55)

Today, many electric machines are used with inverters/converters instead of direct grid connection. This development is respected in IEC 60034-30-2 which is yet to be finally defined as a standard. It will cover converter-fed variable-speed drives and new machine types, e.g. permanent-magnet synchronous machines or wound-rotor synchronous machines (57).

However, some systems are yet to be covered in standard proposals. Among others, these are variable-speed drives with non-sinusoidal voltages, e.g. DC motors or switched reluctance motors, very high and very low speed drives, motors completely integrated into a machine, motors with integrated frequency converters or motors for extended temperature ratings below $-20\text{ }^{\circ}\text{C}$ or above $60\text{ }^{\circ}\text{C}$. Some of these could, however, be tested as a complete power drive system.

A further development step is the introduction of IE5 efficiency standard. Its goal will be to reduce the losses by some 20% relative to IE4. With today's technologies, this goal is not yet reachable and further research is necessary.



Motor type		IE1	IE2	IE3	IE4	IE5
Three-phase cage-rotor induction motors (ASM)	Random wound windings; IP2x (open motors)	Yes	Yes	Yes	Difficult	No
	Form wound windings; IP2x (open motors)	Yes	Yes	Difficult	No	No
	Random wound windings; IP4x and above (enclosed motors greater than 0.75 kW)	Yes	Yes	Yes	Difficult	No
	Random wound windings; IP4x and above (enclosed motors less than or equal to 0.75 kW)	Yes	Yes	Yes	Difficult	No
	Form wound windings; IP4x and above	Yes	Yes	Yes	Difficult	No
Three-phase wound-rotor induction motors		Yes	Yes	Yes	Difficult	No
Single-phase induction motors	Start capacitor	Difficult	No	No	No	No
	Run capacitor	Yes	Difficult	No	No	No
	Start/run capacitor	Yes	Difficult	No	No	No
	Split-phase	Difficult	No	No	No	No
Synchronous motors	Line-start permanent-magnet (LSPM ^a)	Yes	Yes	Yes	Difficult	No
^a Line-start permanent-magnet motors have limitations on their line-start capabilities with respect to torque and external inertia and may not be suitable for all types of applications.						

Figure 97: Motor technologies and their energy-efficiency potential in IEC 60034-30-1 (57)

Comparison of the Efficiency of different Machine Types

An often demanded question is a comparison of the efficiency of the different types of electric machines. As a first statement, this isn't possible in a generally valid way. Furthermore, even different machines of the same type and the same power level can provide different maximum efficiencies. Depending on the load cycle, especially for variable-speed and variable-load machines e.g. in electric vehicles, a machine with lower maximum efficiency can have a higher load cycle efficiency.

In general, it is always necessary to evaluate the expected load cycle of a machine, i.e. constant operation (fans, pumps etc.) vs. variable-speed variable-load operation. It is further important to have knowledge of the efficiency in the whole operating range of different machines to evaluate the cycle efficiency. With different machines and/or different machine types it is then possible to compare them. The



choice of the “right” machine for one specific task of course needs further evaluation of multiple other parameters such as costs, weight, power density, robustness, temperature limitation, cooling possibilities, maintenance demands and control complexity.

For a rough estimation of the performance of different machine types, Figure 98 shows a comparison of the maximum efficiencies for different machine types, permanent magnet synchronous machine (PMSM), synchronous reluctance machine (SynRM), induction machine (IM), switched reluctance machine (SRM) and DC machine, at power ratings from 1 kW to 1000 kW. The efficiency data is exemplary and there may be machines of the same type and same power rating with worse or even slightly better maximum efficiency.

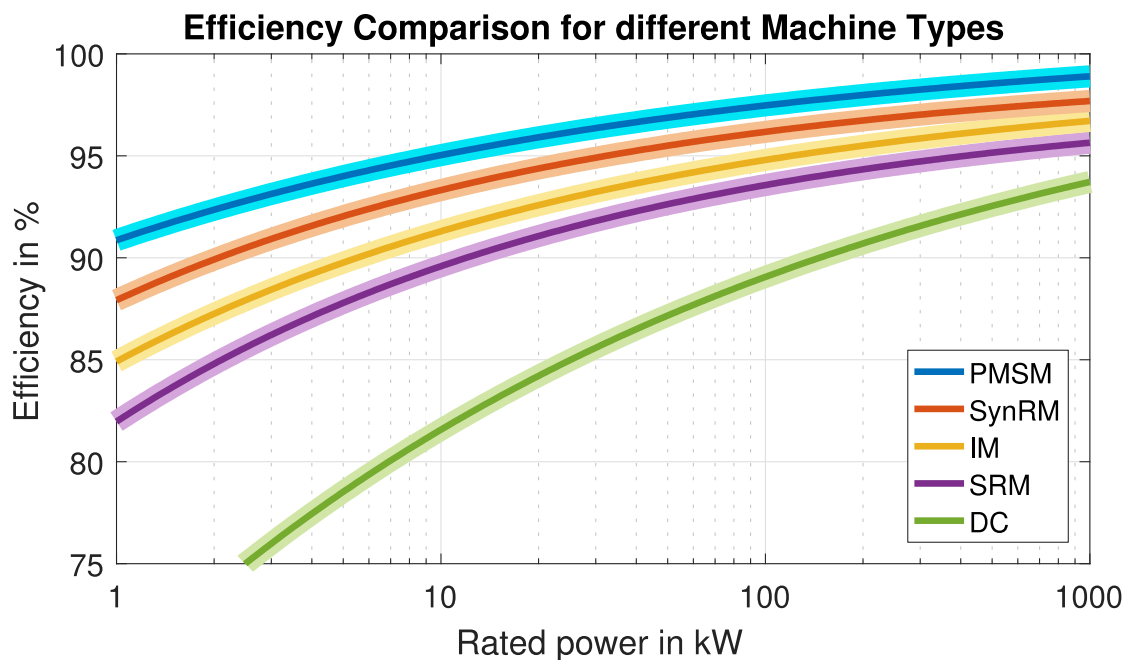

Figure 98: Efficiency comparison for different machine types with exemplary data from i.a. (58), (59)

It is important to consider again at this point that **Figure 98 cannot be used alone for a decision pro or contra a specific machine type**. There are many other factors that influence this decision as already stated above.



Temperature Classes of Winding Insulation

The most critical temperature in an electric machine is mostly the winding hot spot temperature. This temperature depends on different influencing parameters such as machine design specifications or operation boundary conditions (e.g. ambient temperature). In inverter driven machines, the stress on the electrical insulation is especially high due to high voltage surges. Consequently, a proper choice of winding insulation material is necessary that takes respect to the different influences.

The NEMA (National Electrical Manufacturers Association) standard defines different insulation classes which limit the maximum allowable operating temperature of the insulation material (60):

Temperature Allowance Class:	Maximum Operation Temperature Allowed:
A	105 °C
B	130 °C
F	155 °C
H	180 °C
R	220 °C

Table 6: Temperature classes of winding insulation (60)

These classes are part of DIN EN 60085, too.

In general an electric machine should not be operated above the maximum allowed temperature. The insulation classes are directly related to motor life, as for example a machine operated at 180 °C will have an estimated life of around 300 hours with Class A insulation whereas it will have around 8500 hours with Class F insulation. This is due to the Arrhenius law that each 10 °C of temperature rise reduces the lifetime by one half (61).



Cooling of Electric Machines

Electric machines can be cooled in different ways. Even no cooling is possible. The following list provides a rough separation of common cooling methods:

- TENV (totally enclosed, not ventilated)
- Fan-cooled (surface)
- External fan
- Liquid-cooled

The TENV machines are not actively cooled as they are totally enclosed. Heat dissipation is done by radiation and conduction to the outer environment. The fan-cooled type normally has a fan mounted on its own rotor shaft whereas the external-fan-cooled type is equipped with an externally powered fan.

The liquid cooled machines can further be separated by their cooling liquid, for example water or oil. A common solution is cooling of the machine housing (mantle cooling), but multiple other methods exist, too. Some of them are direct oil cooling, where oil is directly used on the active parts of the machine, or rotor cooling.

The cooling method directly influences the design of an electric machine as high current densities require good cooling of the machine. As a consequence, TENV machines usually have lower power ratings and very low power densities.



List of Abbreviations

BLDC	Brushless DC Machine
DFOC	Direct Field Oriented Control
DTC	Direct Torque Control
emf	Electro Motive Force
FOC	Field Oriented Control
IFOC	Indirect Field Oriented Control
IM	Induction Machine
IPMSM	Interior Permanent Magnet Synchronous Machine
PM	Permanent Magnet Machine
PMSM	Permanent Magnet Synchronous Machine
SMPMSM	Surface Mounted Permanent Magnet Synchronous Machine
SRM	Switched Reluctance Machine
SynRM	Synchronous Reluctance Machine
TENV	Totally Enclosed Not Ventilated
VR	Variable Reluctance
VSI	Voltage Source Inverter



List of Figures

Figure 1: Stator and Rotor of an induction motor (1)	6
Figure 2: Distributed winding in stator (2)	6
Figure 3: Squirrel-cage rotor (left) and slip-ring rotor (right) (3)	6
Figure 4: Torque-vs.-speed diagram of the IM (4)	8
Figure 5: Influence of the rotor resistance (4)	9
Figure 6: Influence of the shape of rotor bars (4), (5)	9
Figure 7: Star- and delta-connected IM (4)	10
Figure 8: Star-Delta-Switching using contactors (4)	10
Figure 9: Torque for V/f control (4)	11
Figure 10: Field-oriented control drive structure (6)	13
Figure 11: Operating range of the induction motor (4)	14
Figure 12: Normalized current and power factor over torque (4)	15
Figure 13: Constant (a) and optimized (b) flux linkage reference values over speed and torque (4)	15
Figure 14: Name plate of an induction machine (9)	16
Figure 15: Doubly-fed induction generator connected to a wind turbine (10)	18
Figure 16: One-Phase Induction Motor as Capacitor Motor (4)	19
Figure 17: Inner rotor surface mounted non-salient PMSM with concentrated windings for hybrid vehicle application (13)	21
Figure 18: Cross section of a salient permanent magnet synchronous machine (IPMSM) with distributed windings (14)	21
Figure 19: Cross section of a salient externally excited synchronous machine (left), non-salient permanent synchronous machine (PMSM/SMPMSM) (center) and a salient interior permanent magnet machine (IPMSM) (right) (6)	21
Figure 20: Concentrated (top) vs. distributed (bottom) windings (15)	23
Figure 21: Torque as a function of load angle at constant voltage operation (4)	24
Figure 22: Short circuit torque and current compared to rotor speed (6)	26
Figure 23: Cross section of a synchronous reluctance machine by ABB (16) (left), and a cross section (6) (right)	29
Figure 24: Magnetic flux paths within the synchronous reluctance machine with anti-clockwise rotation (4)	29
Figure 25: Comparison of a synchronous reluctance machine and an induction machine by ABB (16)	31
Figure 26: Stator and rotor of a permanent magnet DC motor (17)	32
Figure 27: Stator and rotor of an externally excited DC motor and schematic of a parallel wound DC machine (1)	32
Figure 28: Cross section of a permanent magnet DC machine with two possible commutator positions (6)	32



Figure 29: Compensation windings and commutation pole of a separately excited DC machine (4).....	33
Figure 30: Separately excited DC machine (4)	34
Figure 31: Torque-speed characteristic curves of a separately excited DC machine (4).....	35
Figure 32: Series wound DC machine (4).....	36
Figure 33: Torque-speed characteristic curve of the series wound machine (4).....	36
Figure 34: Parallel wound DC machine (4)	37
Figure 35: Operating limits of the separately excited DC machine (4).....	39
Figure 36: Separately excited machine with buck chopper (4)	42
Figure 37: Separately excited machine with boost chopper (4)	42
Figure 38: Separately excited machine with 4 quadrant converter (4)	42
Figure 39: Separately excited machine in single-phase net (4)	42
Figure 40: Internal rotor BLDC motor schematic (22).....	44
Figure 41: Stator (left) and outer rotor (right) BLDC (23)	44
Figure 42: Control of a BLDC motor with Hall sensors (left), exemplary hall sensor output and back emf waveforms (right) (24).....	46
Figure 43: A 3 phase, 2 pole pair, 12-8 SRM (25)	49
Figure 44: Rotation caused by reluctance force (26)	49
Figure 45: Continuous rotation of switched reluctance motors (4).....	51
Figure 46: Torque and power over speed curve of a SRM (6)	52
Figure 47: Equivalent circuit of one phase of a switched reluctance machine (6).....	52
Figure 48: SR drive with asymmetric half-bridge converter topology (6).....	53
Figure 49: Current flow of the magnetization state (4)	54
Figure 50: Current flow of the free-wheeling state (4).....	54
Figure 51: Current flow of the de-magnetization state (4)	55
Figure 52: Electrical cycle for phase A (6)	55
Figure 53: Operating in low speed (6)	57
Figure 54: Operating in high speed (6).....	58
Figure 55: Torque production of a three phase SRM (4).....	58
Figure 56: Torque production of a four phase SRM (4)	59
Figure 57: Stepper Motor (28)	60
Figure 58: Variable reluctance stepper motor (29).....	61
Figure 59: Stepping sequence for variable reluctance stepper (29)	61
Figure 60: Permanent magnet stepper motor (29).....	62
Figure 61: Example of permanent magnet stepper motor (30)	62
Figure 62: Coils of the example permanent magnet stepper motor (30)	62
Figure 63: Position hold by current in two phases (31)	62
Figure 64: Simplified permanent magnet stepper in wave drive (29).....	63
Figure 65: Simplified permanent magnet stepper in full-step drive (29).....	64
Figure 66: Simplified permanent stepper motor in half step drive (29)	64
Figure 67: Hybrid synchronous stepper motor (29).....	65
Figure 68: Simplification of hybrid stepper motor (29)	65



Figure 69: Hybrid stepper motor rotation sequence (29)	66
Figure 70: Bipolar and unipolar winding arrangements (32)	66
Figure 71: Switches for bipolar and unipolar motor (34)	67
Figure 72: Speed torque characteristics (29).....	68
Figure 73: Specification of a hybrid synchronous stepper motor (38)	69
Figure 74: Operation quadrants of electrical drives (4)	71
Figure 75: Lorentz force on a current carrying conductor in a magnetic field (4).....	72
Figure 76: Right-hand rule (4)	72
Figure 77: Relationship between current / flux linkage space vectors and torque (6).....	73
Figure 78: Reluctance force in a magnetic circuit (4).....	74
Figure 79: Producing flux linkage with one winding (4).....	75
Figure 80: Flux linkage of a three-phase system (4)	76
Figure 81: Generation of an induced voltage (4).....	77
Figure 82: Optical incremental position encoder (4)	78
Figure 83: Magnetic incremental position encoder (schematic) (4).....	79
Figure 84: Magnetic incremental position encoder (electrical pulses) (4).....	79
Figure 85: Resolver for absolute position measurement (4)	80
Figure 86: Examples of rotor shapes of the VR-type resolvers (4).....	81
Figure 87: VR-Resolver: Change of inductance as function of the rotor position (4)	81
Figure 88: Arrangement of the $\alpha\beta$ -coordinate system (46)	83
Figure 89: Transformations of a three-phase system (4)	85
Figure 90: Field-oriented control drive structure (6).....	86
Figure 91: Block diagram of indirect field-oriented control (IFOC) (47)	87
Figure 92: Block diagram of direct field-oriented control (DFOC) (48)	87
Figure 93: Block diagram of direct torque control (DTC) (50)	88
Figure 94: Breakdown of losses in an electric machine (exemplary for an induction machine) (51).....	89
Figure 95: B(H)-characteristic of magnetic materials (53) 1 = soft-magnetic material, e.g. iron / 2 = hard-magnetic material, e.g. permanent magnets.....	90
Figure 96: IE efficiency classes for 4-pole (2 pole pairs) motors at 50 Hz (55)	93
Figure 97: Motor technologies and their energy-efficiency potential in IEC 60034-30-1 (57)	94
Figure 98: Efficiency comparison for different machine types with exemplary data from i.a. (58), (59).....	95



List of Tables

Table 1: Comparison of different machine types	5
Table 2: Description of the name plate data of the induction machine (9)	16
Table 3: Basic formulas of the induction machine (9)	17
Table 4: Typical SRM machine configuration (6)	50
Table 5: Switching states and resulting phase voltage of asymmetrical half-bridge (6)	53
Table 6: Temperature classes of winding insulation (60)	96



References

1. **learnengineering.** <http://www.learnengineering.org/2013/08/three-phase-induction-motor-working-squirrel-cage.html>. [Online]
2. <http://forum.electricunicycle.org/>. <http://forum.electricunicycle.org/topic/3909-euc-motor-drive/?page=2>. [Online]
3. *ECourses Online - Module 5. Induction motors - Lesson 17 Construction of Induction Motors.* [Online]
http://ecoursesonline.iasri.res.in/pluginfile.php/3697/mod_resource/content/1/Lesson_17.htm.
4. **Institute for Power Electronics and Electrical Drives (ISEA), RWTH Aachen.** Lecture Notes etc.
5. **E. Hering, A. Vogt, K. Bressler.** *Handbuch der elektrischen Anlagen und Maschinen.* s.l. : Springer, 1999.
6. **De Doncker, R.W. De, Pulle, Duco W.J. und Veltman, Andre.** *Advanced Electrical Drives.* s.l. : Springer, 2011.
7. **Hasse, K.** *Zur Dynamik drehzahl geregelter Antriebe mit stromrichter gespeisten Asynchron-Kurzschlussläufermaschinen.* [Hrsg.] TH Darmstadt. 1968.
8. **Blaschke, F.** *The principle of field orientation as applied to the new transvector closed-loop control system for rotating field machines.* [Hrsg.] Siemens Review XXXIX(5):217-219. 1972.
9. *energie.ch - Asynchronmaschine.* [Online] <http://www.energie.ch/asynchronmaschine>.
10. **Wikimedia Commons.** *Wikipedia.* [Online]
<https://en.wikipedia.org/wiki/File:Doublyfed06.svg>.
11. *Behavior of Multiphase Induction Machines with Unbalanced Stator Windings.* **Zarri, L., et al., et al.** 2011. *Diagnostics for Electric Machines, Power Electronics Drives.* S. 84-91.
12. **Müller, Germar.** *Berechnung elektrischer Maschinen.* 2008.
13. **Hybrid-Autos.** [Online] [Zitat vom: 07. 06 2016.] <http://www.hybrid-autos.info/Technik/E-Maschinen/>.
14. **Saurabh Kumar Sinha.** linkedin. [Online] [Zitat vom: 10. 06 2016.]
<https://www.linkedin.com/pulse/global-permanent-magnet-motor-market-research-report-saurabh-sinha>.
15. **JMAG.** [Online] [Zitat vom: 15. 07 2016.] <https://www.jmag-international.com/newsletter/201401/img/201401-0403.gif>.
16. **ABB .** www.abb.com. [Online] [Zitat vom: 07. 06 2016.]
17. **CVEL.** *Automotive Electronics.* [Online] [Zitat vom: 17. 08 2016.]
<http://images.google.de/imgres?imgurl=http%3A%2F%2Fwww.cvel.clemson.edu%2Fauto%2Factuators%2Fimages%2Fchaudhary->



DCmotor.png&imgrefurl=http%3A%2F%2Fwww.cvel.clemson.edu%2Fauto%2Factuators%2Fmotors-dc-brushed.html&h=371&w=500&tbnid=fJ3C-sAu_U2CBM%3A&docid=N.

18. **Industrial electrical.** DC Motor brush Life. [Online] [Zitat vom: 17. 06 2016.] <http://industrialelectricalco.com/wp-content/uploads/2014/01/DC-Motor-Brush-Life-White-Paper.pdf>.
19. **brighthubengineering.** [Online] [Zitat vom: 17. 06 2016.] <http://www.brighthubengineering.com/diy-electronics-devices/123625-understanding-shunt-wound-dc-motors/>.
20. **electrical4u.** [Online] [Zitat vom: 16. 06 2016.] <http://www.electrical4u.com/speed-control-of-dc-motor/>.
21. **electricaleasy.** [Online] [Zitat vom: 06. 06 2016.] <http://www.electricaleasy.com/2015/05/brushless-dc-bldc-motor.html>.
22. **Emworks.** [Online] [Zitat vom: 06. 06 2016.] http://www.emworks.com/media/images/product/large/Brushless-DC-Motor-6_3.png.
23. **Nanotec.** BLDC Motoren. [Online] [Zitat vom: 17. 06 2016.] <http://de.nanotec.com/support/technik-wiki/bldc-motoren/>.
24. **Infineon.** Sensorless BLDC Motor Drive. [Online] [Zitat vom: 17. 06 2016.] <http://www.infineon.com/dgdl/an-1187.pdf?fileId=5546d462533600a40153559af4db1155>.
25. **Goldberg, Lee H.** <http://www.digikay.com/en/articles/techzone/2012/sep/ev-drive-electronics-evolve-to-support-rare-earth-free-motor-technologies>. [Online]
26. **Guoqing Xu, Chunhua Zheng, Yanhui Zhang1, Kun Xu and Jianing Liang.** Energy Efficiency of Electric Vehicles – Energy Saving and Optimal Control Technologies.
27. **Amin, Muhammad.** *Operation, Construction, and Functionality of Direct Current Machines.* 2015.
28. <http://pws-robotica.roland-kamphuis.nl/?id=techniek>. [Online]
29. **Kuphaldt, Tony R.** https://www.ibiblio.org/https://www.ibiblio.org/kuphaldt/electricCircuits/AC/AC_13.html. [Online]
30. <https://www.element14.com>. [Online]
31. **Athani, V.V.** *Stepper Motors : Fundamentals, Applications And Design.* 1997.
32. <https://www.circuitspecialists.com/blog/unipolar-stepper-motor-vs-bipolar-stepper-motors/>. [Online]
33. **wikipedia.** https://en.wikipedia.org/wiki/Stepper_motor. [Online]
34. **haydonkerk.** <http://www.haydonkerk.com/Resources/StepperMotorTheory/tabid/192/Default.aspx>. [Online]
35. **motioncontrolproducts.** <http://www.motioncontrolproducts.com/pages/applications-how-to-select-stepper-motor.php>. [Online]
36. http://www.orientalmotor.com/products/pdfs/2012-2013/A/usa_st_pk_motor_only.pdf. [Online]



-
37. http://motion.schneider-electric.com/downloads/catalogs/step_motors_catalog2012.pdf. [Online]
38. <https://www.sparkfun.com/products/9238>. [Online]
39. **amci**. <https://www.amci.com/industrial-automation-resources/plc-automation-tutorials/stepper-vs-servo/>. [Online]
40. <https://www.amci.com/industrial-automation-resources/plc-automation-tutorials/stepper-vs-servo/>. [Online]
41. **Sean DeHart, Smriti Chopra, Hannes Daepf**. ume.gatech.edu/mechatronics_course/Motors_F09.ppt. [Online]
42. **fullingmotor**. http://www.fullingmotor.com/catalogo_FULLLING/files/assets/basic-html/page72.html. [Online]
43. http://www.machinetoolhelp.com/Automation/systemdesign/stepper_dcservo.html. [Online]
44. **Schröder, Dierk**. *Elektrische Antriebe - Regelung von Antriebssystemen*. s.l. : Springer Vieweg, 2015. ISBN 978-3-642-30096-7.
45. **Veltman, Andre, Pulle, Duco W. J. und De Doncker, Rik W**. *Fundamentals of Electrical Drives*. s.l. : Springer, 2007.
46. **Wikimedia Commons**. Wikipedia. [Online]
<https://commons.wikimedia.org/wiki/File:Raumzeigerdarstellung.svg>.
47. **Wikipedia**. *IFOC.jpg - Wikipedia, The Free Encyclopedia*. [Online]
<https://commons.wikimedia.org/wiki/File:IFOC.jpg>.
48. —. *DFOC.jpg - Wikipedia, The Free Encyclopedia*. [Online]
<https://commons.wikimedia.org/wiki/File:DFOC.jpg>.
49. **Kazmierkowski, M. P., et al., et al**. High-Performance Motor Drives. *IEEE Industrial Electronics Magazine*. 2011, Bd. 5, 3.
50. **Wikipedia**. *DTC block diagram.JPG - Wikipedia, The Free Encyclopedia*. [Online]
https://en.wikipedia.org/wiki/File:DTC_block_diagram.JPG.
51. **Siemens**. *ABC of Motors*. 2009.
52. **Wikipedia**. *Skin effect - Wikipedia, The Free Encyclopedia*. [Online]
https://en.wikipedia.org/wiki/Skin_effect.
53. **Binder, Andreas**. *Elektrische Maschinen und Antriebe*. s.l. : Springer, 2012.
54. **Brander, Thomas, et al., et al**. *Trilogie der induktiven Bauelemente (Würth Elektronik)*. [Online] http://www.wonline.de/web/de/electronic_components/extra_pbs/Wikipedia.php.
55. **ABB**. *Technical note on IEC 60034-30*. [Online]
[http://www04.abb.com/global/seitp/seitp202.nsf/c71c66c1f02e6575c125711f004660e6/20a5783a8b31d05748257c140019cc05/\\$FILE/TM025+EN+RevC+01-2012_IEC60034-30.lowres.pdf](http://www04.abb.com/global/seitp/seitp202.nsf/c71c66c1f02e6575c125711f004660e6/20a5783a8b31d05748257c140019cc05/$FILE/TM025+EN+RevC+01-2012_IEC60034-30.lowres.pdf).



-
56. **Umweltbundesamt.** Datenblatt zur Verordnung (EG) 640/2009. [Online]
http://www.umweltbundesamt.de/sites/default/files/medien/481/dokumente/datenblatt_640-2009_elektromotoren.pdf.
57. **Doppelbauer, Martin.** www.motorsummit.ch. [Online]
http://www.motorsummit.ch/data/files/MS_2012/presentation/ms12_doppelbauer_update.pdf.
58. **ABB.** *ABB review 1/11*. [Online]
https://library.e.abb.com/public/46ab92b48dda3f248325785c005a701a/ABB%20Review%20ENG%201_11-0204_CMArticle.pdf.
59. **Siemens.** *Siemens DC motors, Catalog DA 12 2008*. [Online]
<http://w3app.siemens.com/mcms/infocenter/dokumentencenter/Id/Documentsu20Catalogs/dc-motor/da12-2008-en.pdf>.
60. **Wikipedia.** *Insulation system - Wikipedia, The Free Encyclopedia*. [Online]
https://en.wikipedia.org/wiki/Insulation_system.
61. —. *Arrhenius equation - Wikipedia, The Free Encyclopedia*. [Online]
https://en.wikipedia.org/wiki/Arrhenius_equation.
62. *A Strategy for Improving Reliability of Field-Oriented Controlled Induction Motor Drives.*
Liu, T., Fu, J. und Lipo, T. 5, Sep 1993, IEEE Transactions on Industry Applications, Bd. 29, S. 910-918.
63. **explainthatstuff.** <http://www.explainthatstuff.com/>. [Online]
64. **set-tech.** [Online] <http://www.set-tech.com.tw/en/bldc-motor-control.html>.
65. <http://www.allaboutcircuits.com/>. [Online]
66. **motor-design.** <http://www.motor-design.com/speed.php>. [Online]